

PROPRIETARY DATA
 This document and information contained hereon is the property of WESTCOR and may not be reproduced, used or disclosed without prior written permission of WESTCOR, a division of VICOOR Corporation.

REVISIONS				
ECC	REV	DESCRIPTION	DATE	APPROVED
687	A	CHANGED MATERIAL	7-25-97	RBJ
730	B	CHG: NOTE 2J, WAS L = 88 UH.	12-18-97	RBJ
1023	C	CHG: NOTES 2.1, & 3.3 PER ECC	05-15-00	RBJ
---	C1	ADD PERMACORE 87-9040-26	11/10/00	RBJ
---	C2	CERT. OF COMPLIANCE CHANGES	6/5/03	RO
1417	C3	ADD SOURCE SHANGHI SUPER ELECT	09/07/04	RBJ
1462	D	ADDED ROHS SPEC NOTE	06/21/05	LCK
1543	E	TAPE # 1350F WAS # 1298	09/01/05	LCK

NOTES UNLESS OTHERWISE SPECIFIED

1. MATERIALS: UL RECOGNIZED 94V-2 FLAMMABILITY RATING CLASS B (130°C) REQUIRED.

1.1 CORE: TOROID, $\mu = 5000$

MAGNETICS ZJ-43306-TC OR
 PERMACORE 87-9040-26 OR

SHANGHAI SUPER LIGHT ELECTRONICS COMPONENTS LTD.
 P/N 133X19X635-C, MATERIAL RSK (CAN BE USED IF ROHS COMPLIANT)

1.2 WIRE: UL RECOGNIZED 130°C MINIMUM RATING MAGNET WIRE, APPROVED MFR: ESSEX
 OTHER MFR HAS TO BE ROHS COMPLIANT CERTIFIED BEFORE USE.

1.3 OUTER WRAP: 3M #69 OR #1350F.

1.4 MATERIAL CERTIFICATE OF COMPLIANCE REQUIRED.

2. SPECIFICATIONS

2.1 L = 82 UH MIN/COIL (1 KHZ, 4Vrms)

2.2 DCR = 0.6 OHMS MAX/COIL

2.3 POWER LOSS = 4.3 W MAX @ 60A/COIL

2.4 HI-POT TEST COIL TO COIL, 300VDC TO INSURE INTEGRITY OF WINDING
 INSULATION COVERING HAS NOT BEEN BREACHED

3. CONSTRUCTION:

3.1 WIND COILS EVENLY SPACED (NOTE POLARITY)

3.2 REMOVE INSULATION AND TIN LEADS APPROX FLUSH WITH THE COIL AS SHOWN
 (I.E. COIL MUST REST FLAT ON PCB). LEADS MUST BE TANGENT TO THE CORE.

3.3 WRAP INDUCTOR WITH TAPE, (PER NOTE 1.3). MARK PART NUMBER AND REVISION
 IN (BLACK) APPROX. WHERE SHOWN, USING A PERMANENT MARKING METHOD.

3.4 COIL LEADS MUST FUNCTION FIT INTO A JIG MADE PER THE DIMENSIONS SHOWN
 ON "FORMING JIG MTS HOLE PATTERN" TO INSURE PROPER POSITION AND ANGLE.

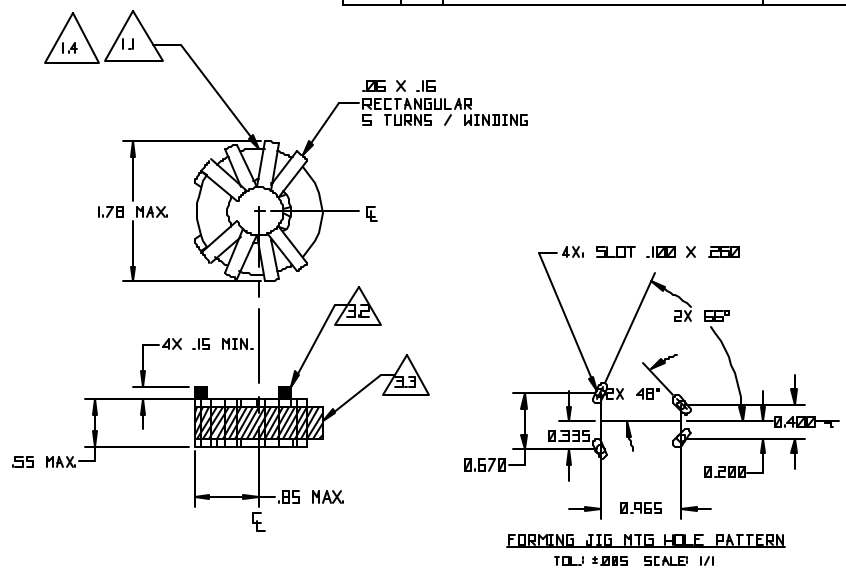

NOTE: CERTIFICATION OF MATERIAL COMPLIANCE REQUIRED.
 COMPLETED ASSEMBLY MUST BE (ROHS) COMPLIANT
 PER VICOR SPEC CST-0001.

		UNLESS OTHERWISE SPECIFIED DIMENSIONS ARE IN INCHES TOLERANCES ARE:	CONTRACT NO. ---		WESTCOR a division of VICOOR Corp.	
		FRACTIONS DECIMALS ANGLES .XX ± .05 .XXX ± .020	APPROVALS DATE			
		MATERIAL SEE NOTES	DRAWN M. ITURRALDE 12/3/96		IND COMMON MODE 110UH 60A	
---	SEE M15	FINISH ---	CHECKED L.KING 7/26/97		SIZE	CAGE CODE
NEXT ASSY	USED ON		APPROVED R.BORRINO 7/25/97		---	---
APPLICATION		DO NOT SCALE DRAWING	DESIGNED R.CALLERO 2/02/96		DWG NO.	REV
					36-00029-07	E
					SCALE NTS	FILENAME 36-00029-07.DWG SHEET 1 OF 1