

3 Phase MegaPAC™ 4kW MegaPAC™ AC-DC Switchers



Design Guide and “Quick Install” Instructions



www.vicorpower.com

TABLE OF CONTENT

Overview of Product.....	3
Mechanical Considerations.....	4
MegaPAC Do's and Don'ts.....	4
Technical Description.....	5
Configuring and Reconfiguring MegaPACs.....	6
ConverterPAC Description.....	7
ConverterPAC Output and Connector Pin Identification.....	8
Part Numbering.....	9
Quick Install Instructions.....	11
Mechanical Drawings: 3 Phase MegaPAC.....	13
Mechanical Drawings: 4 kW MegaPAC.....	14
Interface Connections.....	15
Specifications.....	21
Current Share Boards.....	23
Low Leakage Version.....	24

3 Phase MegaPAC and 4kW MegaPAC™

AC-DC Switchers

Overview

The 3 Phase MegaPAC and 4kW MegaPAC are field-configurable, single or multiple output switchers providing up to 2,000 W (3 Phase MegaPAC) to 4,000 W (4kW MegaPAC) of output power. The chassis has 10 slots and can provide up to 20 regulated, fully isolated outputs. It achieves power densities of 4.4 Watts per cubic inch (3 Phase MegaPAC) to 7.8 Watts (4kW MegaPAC) per cubic inch. The dimensions of the 3 Phase MegaPAC are 4.9"H x 7.5"W x 12.3"L (124,5mm x 190,5mm x 312,4 mm) and the dimensions of the 4kW MegaPAC are 4.9"H x 7.5"W x 14"L (124,5mm x 190,5mm x 355,6mm). The 4kW MegaPAC is longer than the 3 Phase MegaPAC to accommodate a 2nd fan.

A complete power supply is configured at the factory by selecting and inserting up to ten same length slide-in output assemblies called ConverterPACs. ConverterPACs incorporate one or two VI-200/VI-J00 and/or Maxi Vicor DC to DC converters and are available in a wide selection of outputs and power levels. The net result is a power supply that offers the advantages of a custom supply, but is assembled from standard and modular building blocks. For detailed information about ConverterPACs, refer to the ConverterPAC information sheet. The 4kW MegaPAC uses VI-200/VI-J00 and Maxi Vicor DC to DC converters while the 3 Phase MegaPAC uses VI-200/VI-J00 Vicor DC to DC converters.

Manufactured at Westcor, a division of Vicor, the entire family of MegaPAC power supplies is completely user-configurable. If output requirements change, i.e., more power or a different output voltage is needed, upgrading is easy: simply unlock a single screw and replace the slide-in ConverterPAC with one of the same length and has the desired voltage power rating. For additional flexibility, same length ConverterPACs can be connected in parallel to increase output power (booster ConverterPACs), or in series for higher voltages (total output voltage should not exceed 400V). The driver is to the left of the boosters when looking at the output end of the supply. A user-friendly interface provides control and output sequencing capability, in addition to useful status indicators. Please consult our Applications Engineering Department if you have other special requirements.

Standard Features

- Input: 3Ø 208/240 Vac Wye or Delta, 1Ø 180–264 (47–500Hz) or 260–352 Vdc
- Power Output: 3 Phase MegaPAC: 2,000W with 3Ø input; 1,200W with 1Ø input; 1–20 outputs
4kW MegaPAC: 4,000W with 3Ø input; 1,500W with 1Ø input; 1–20 outputs
- 10 slots (up to 20 outputs)
- Fan cooled (the 4kW MegaPAC has 2 fans)
- Full power to 45°C; half power to 65°C
- Power factor correction (passive) 0.92 PF (3Ø input)
- Conducted EMI meets EN 55022 Level A
- AC Power OK and AC Power Fail status signals
- Output Sequencing and General Shutdown (Consult Applications Engineering for automatic sequencing circuitry.)
- Autosense (Refer to page 11 and page 15 for more information on Autosense)
- Overcurrent protection on all outputs
- Overtemperature limiting (not applicable with VI-J00 modules)
- Output overvoltage protection (not applicable with VI-J00 modules)
- Ride-Through time: >20 ms at nominal line (full load)
- Size: **4 kW MegaPAC:** 4.9"H x 7.5"W x 14"L (124,5mm x 190,5mm x 355,6mm) Regular chassis
Size: **3 Phase MegaPAC:** 4.9"H x 7.5"W x 12.3"L (124,5mm x 190,5mm x 312,4mm) Regular chassis
- Safety Agency Approvals: CE Mark, UL, CSA, TUV

Optional Features

- DC OK status signal
- Output voltage adjustment range with built-in potentiometer
- Reversed fan airflow direction
- Industrial-grade screening of output converters
- Current Share Boards - See page 23 and 24

Mechanical Considerations

The 3 Phase MegaPAC and 4kW MegaPAC can be mounted on any of four surfaces using standard 8-32 or 4 mm screws. The chassis comes with four mounting points on each surface; maximum allowable torque is 20lb-in. The maximum penetration is 0.15 in. (3,8mm).

When selecting a mounting location and orientation, the unit should be positioned so air flow is not restricted. Maintain a 2" minimum clearance at both ends of the 3 Phase MegaPAC and 4kW MegaPAC and route all cables so airflow is not obstructed. The standard unit draws air in at the fan side/AC input side and exhausts air out the load side. If airflow ducting is used, use caution, as sharp turns could present back pressure to the 3 Phase MegaPAC and 4kW MegaPAC. The fans move approximately 50 CFM of air for the 4kW MegaPAC and 30 CFM for the 3 Phase MegaPAC. The 4kW MegaPAC has a second fan for additional cooling capabilities.

Avoid excessive bending of output power cables after they are connected to the 4kW MegaPAC or 3 Phase MegaPAC. For high-current outputs, use cable ties to support heavy cables in order to minimize mechanical stress on output studs. Be careful not to short-out to neighboring output studs. The 3 Phase MegaPAC and 4kW MegaPAC is supplied with serrated, flanged hex-nuts on all output studs, so thread locking compounds or lock washers are not required. The maximum torque recommended on flanged nuts is 45 lb-in. Never loosen the inner nut on a ConverterPAC. This nut supports the hardware inside the ConverterPAC and is factory torqued.

Avoid applications in which the unit is exposed to excessive shock or vibration levels. In such applications, a shock absorption mounting design is required.

MegaPAC Do's and Don'ts

- For units without Autosense, **do not leave ConverterPAC Sense lines open. Always terminate them at their respective outputs locally or at the load. Use twisted pair 22-24 AWG wire. If ConverterPAC has Autosense, no local sense connection is required.** See page 10 and 14 for more information on Autosense.
- If needed, use Connector Kit # 19-130041 for the 3 Phase/4kW MegaPACs.
- **Always fill all output slots of the MegaPAC. If a slot is not filled with a ConverterPAC, it should be filled with an airblock.** Airblocks are plastic assemblies whose main function is to fill up an empty slot. Any airflow escape from an empty slot, significantly degrade thermal performance **can result in overheating and damage to the power supply.**
- **Do not unplug ConverterPACs while input power is applied. They are not designed for hot-plug applications.**
- **Do not restrict airflow to the unit. Leave 2 inch minimum space in front and behind the supply.** The cooling fan draws air into the unit and forces it out at the output power terminals.
- For power expansion, use booster ConverterPACs. Viewing the unit from the output terminal side, always insert boosters to the right side of the driver.
- Do not use boosters as independent outputs. Disconnecting bus bars will damage booster ConverterPACs.
- Always ensure that output hex-nuts are properly torqued before applying power to supply.
- For booster arrays, **do not remove busbars.**
- Run the output (+/-) power cables next to each other to minimize inductance.
- Wait 5 minutes after shutting off power before inserting or removing ConverterPACs.
- The MegaPACs does not have user serviceable components. They must be returned to the factory for repairs. Contact Customer Service for a RMA number before returning the unit. Do not attempt to repair or modify the power supply in any manner other than the exchange of ConverterPACs as described in this Design Guide.
- Insert proper fault protection at power supply input terminals (i.e., a fuse).
- Use proper size wires to avoid overheating and excessive voltage drop.
- Never loosen the inner nut on a ConverterPAC.
- Verify output nuts are tight before powering up.
- Only use the regular length ConverterPACs in the 3 Phase/4kW MegaPAC chassis. You cannot use any of the Extended Length ConverterPACs which are only used in the EL (Low Noise) products.
- Keep in mind that currently, the UniPAC ConverterPAC can only be used in the 4kW MegaPAC.

Technical Description

The 3 Phase MegaPAC and 4kW MegaPAC are configured by installing same length ConverterPAC assemblies into the chassis. The chassis takes AC input power and performs filtering and rectification functions. The ConverterPACs plug into a high-voltage backplane and provide low-noise, independently regulated and fully isolated outputs.

Input AC mains voltage (L1, L2, L3 and GND) is applied to an agency approved mating plug. The input current is passed through an EMI filter designed to meet EN 55022 Level A before it is passed to a three-phase full-wave bridge rectifier. The rectifier charges storage capacitors and delivers unregulated 300 Vdc to a backplane after passing through a large choke that improves input power factor. The power factor typically exceeds 0.9 depending upon load, line voltage, frequency and line balance. Inrush current is actively controlled with an IGBT and never exceeds 30A peak regardless of hot or cold starts.

A housekeeping supply, isolated from the AC input, powers the brushless DC cooling fan and other input monitoring circuits, in addition to providing an auxiliary +5V power source for the user. **The 4kW MEGAPAC HAS A SECOND FAN FOR EXTRA COOLING.** Excessive input currents caused by loss of a phase or excessive output loading in single phase operation will safely shut down the unit until input power is recycled. This occurs when the peak input current reaches 30A. An analog temperature monitor is provided, as well as overtemperature shutdown. An active-high TTL compatible Enable control is included for each ConverterPAC assembly, as well as an active-low General Shutdown control; the polarities, active-high or active-low, are factory set. The 3 Phase MegaPAC and 4kW MegaPAC can be safely paralleled (with another of its own kind) with accurate current sharing for high power systems. All interface signals are safety isolated using a common floating return.

Upon power-up, all outputs are first disabled to limit the inrush current, and to allow the unregulated bus to reach correct operating levels for ConverterPAC assemblies. The internal housekeeping supply comes up within 500 ms after input power is applied, and the AC Power OK signal asserts to a TTL "1," indicating the input power is OK. The low voltage power outputs come up within 10-20 ms after the AC Power OK asserts to a TTL "1." Output ramp-up time from Enable or General Shutdown is 10-20 ms. Output fall time from Disable is dependent on load, but is typically a few hundred microseconds.

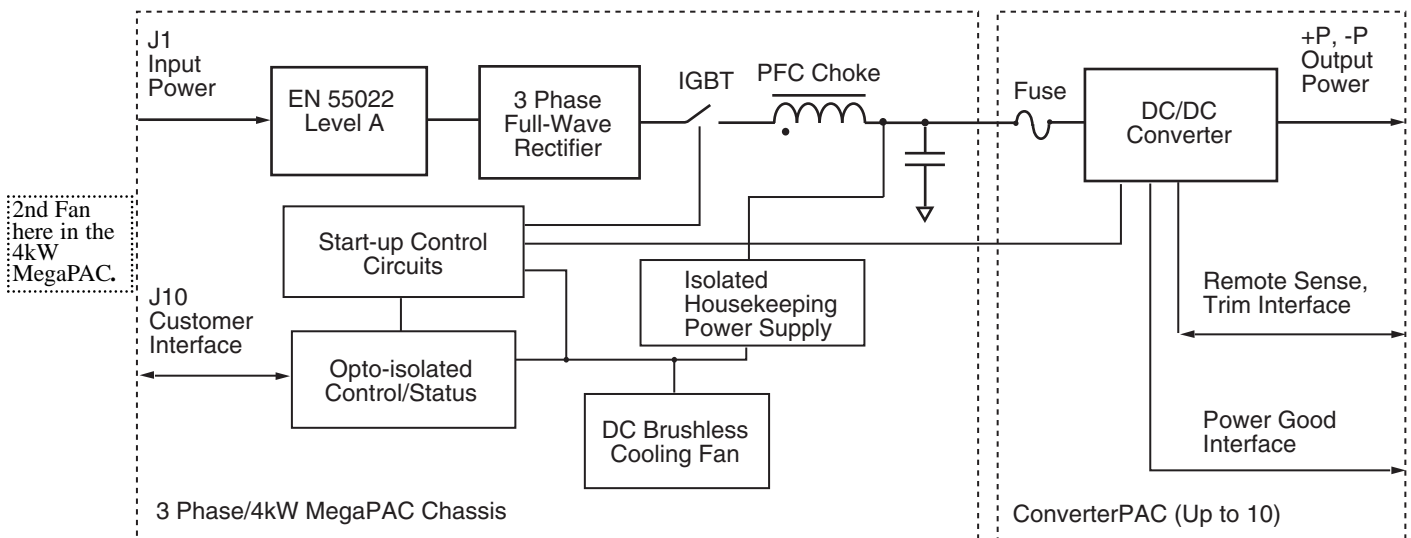

Figure 1. 3 Phase MegaPAC and 4kW MegaPAC Architectures.

Configuring and Reconfiguring MegaPACs

Most ConverterPACs of the same length can be easily added, replaced, or moved by sliding the assemblies in or out of a MegaPAC chassis. They are driver ConverterPACs and can be inserted into any available slot. For outputs greater than 200 Watts, a driver ConverterPAC and one or more booster ConverterPACs will be used. For outputs greater than 500 Watts (in the 4kW MegaPAC), a driver UniPAC and one or more booster UniPACs will be used. Arrays of drivers and boosters should be configured so all boosters are placed in the slots to the immediate right of the driver when looking at the output end of the MegaPAC.

Prior to removing or installing ConverterPACs, you must remove power from the MegaPAC and wait 5 minutes. Failure to do so can result in personal injury or damage to the supply.

Take standard ESD precautions when handling ConverterPACs.

Removing ConverterPACs

ConverterPACs can be removed by loosening the captive screw at the base. Once this screw has been loosened, the ConverterPAC will slide out of the chassis. **Once a ConverterPAC has been removed, the empty slot MUST be filled with either another ConverterPAC of the same length or an airblock.** If the slot is left empty, it will provide an airflow escape and cause failure to the power supply.

Installing ConverterPACs as Drivers

ConverterPACs can be installed in empty slots by simply sliding in the new ConverterPAC and securing the screw at the base. Power and interface connections can be made after the ConverterPAC has been installed.

Installing Booster ConverterPACs to Increase Output Power

ConverterPACs can be paralleled for more power. Additional power to an output is obtained by connecting one or more boosters in parallel with a single driver. The driver can be placed in any open slot. All boosters should be inserted in the slots to the immediate right of the driver, as viewed from the output end of the MegaPAC. Figure 2 shows a driver placed in slots #1 and 3 boosters placed in slots # 2 to 4. After inserting the driver and boosters, they are paralleled using bus bars across the positive and negative output studs. Drivers should not be paralleled with each other. Bus bars between a driver and booster(s) should never be disconnected. For help in identifying boosters and drivers, refer to the Part Numbering section on page 10. Please note that total output voltage should not exceed the converter baseplate-output isolation rating of 400V. For detailed guideline on how outputs should be placed in series, please refer to the Applications note available on the website at www.vicorpower.com.

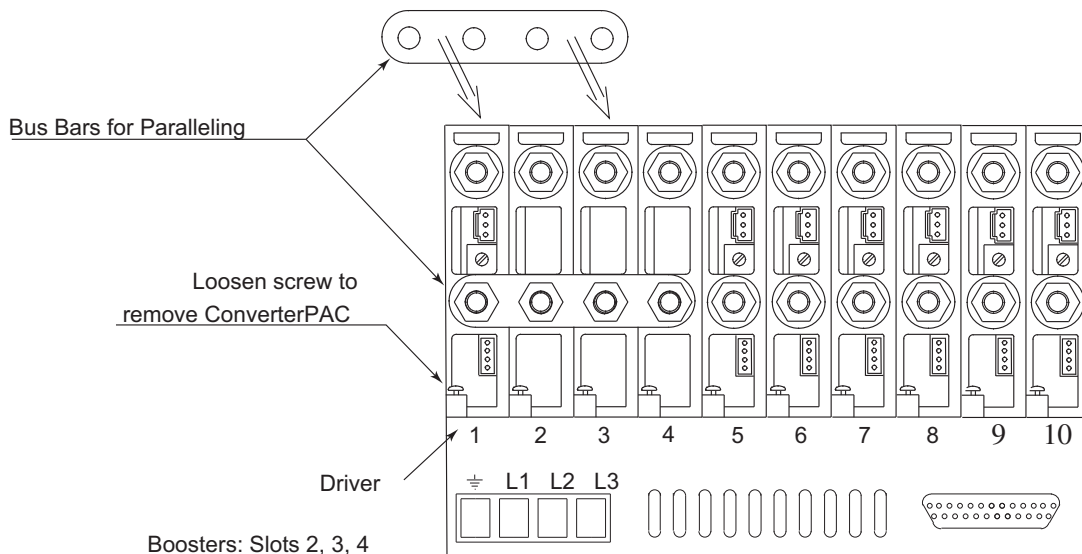

Figure 2. Paralleling ConverterPACs

ConverterPAC Functional Description (See ConverterPAC information sheet for complete information on all ConverterPACs)

ConverterPACs are the family of slide-in output assemblies used in MegaPAC power supplies. Most ConverterPACs of the same length are interchangeable within a MegaPAC or between different AC input chassis. They can be added, moved, or changed as necessary. The following ConverterPACs can be used in the 3 Phase and 4kW MegaPACs.

ModuPAC

The ModuPAC output assembly consists of a **VI-200** Vicor DC to DC converter that converts the unregulated high voltage bus to the desired regulated output voltage. Each ModuPAC can provide up to 200 Watts of power. Multiple ModuPACs can be paralleled in a driver-booster configuration to provide more power.

ModuPAC

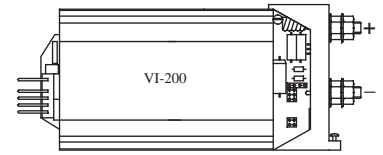

JuniorPAC

The JuniorPAC consists of a **VI-J00** Vicor DC to DC converter that converts the unregulated high voltage bus to the desired regulated output voltage. JuniorPACs can provide up to 100 Watts of output power.

JuniorPAC

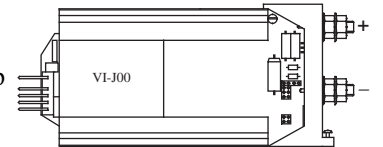

DualPAC

This output assembly consists of two **VI-J00** Vicor DC to DC converters that convert the unregulated high voltage bus to the desired regulated output voltages.

DualPAC

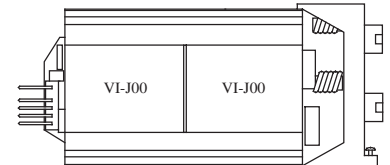

RAMPAC

This output assembly consists of a **VI-J00** Vicor DC to DC converter with a Ripple Attenuator Module (RAM) and is designed for applications requiring low output ripple/noise.

RAMPAC

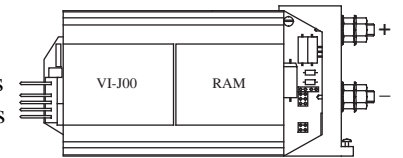

BatPAC

The BatPAC output assembly consists of a **VI-200** BatMod current source that converts the unregulated high voltage bus to the desired regulated output voltage. The BatPAC is a 200 Watts programmable current source that can be configured as a battery charger.

BatPAC

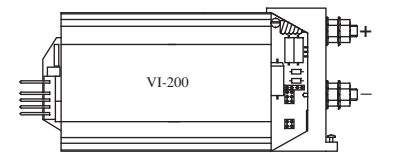

UniPAC

The UniPAC output assembly consists of a **Maxi** Vicor DC-DC module that converts the unregulated high voltage bus to the desired regulated output voltage. UniPACs can provide up to 500W of power. Multiple UniPACs can be paralleled in a driver-booster configuration to provide more power. **The UniPAC can only be used in the 4kW MegaPAC (not in the 3 Phase MegaPAC or any other MegaPACs).**

UniPAC

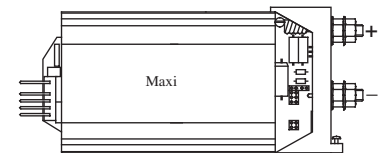

LIST OF CONVERTERPACS USED IN THE 3PHASE/4kWMEGAPACS AND THEIR FEATURES:

<u>ConverterPAC</u>	<u>OVP</u>	<u>OCP</u>	<u>OTL</u>	<u>RS/AS</u>	<u>LS/AS</u>	<u>PG</u>	
<u>TrimPot</u>							
ModuPAC	Std	Std	Std	AS*	AS*	Opt	Opt
JuniorPAC	N/A	Std	N/A	AS*	AS*	Opt	Opt
DualPAC	N/A	Std	N/A	AS*	AS*	N/A	Opt
RAMPAC	N/A	Std	N/A	AS*	AS*	Opt	Opt
BatPAC	N/A	Std	N/A	N/A	N/A	N/A	Std
UniPAC**	Std	Std	N/A	AS*	AS*	Opt	Opt
OVP	Overvoltage Protection (latching)				RS	Remote Sense	
OCP	Overcurrent Protection (auto-recovery)				LS	Local Sense	
OTL	Overtemperature Limiting (latching)				AS	Autosense	
PG	Power Good (DC OK TTL Signal)						

* See page 11 and 15 for more information on Autosense.
 ** **Currently, the UniPAC (XU) can only be used in the 4kW MegaPAC.**

Note: All ConverterPACs mentioned above can be paralleled EXCEPT the DualPAC, JuniorPAC and RamPAC.

ConverterPAC Output and Connector Pin Identification for the 3 Phase/4kW MegaPACs

**ModuPAC
JuniorPAC
RamPAC**

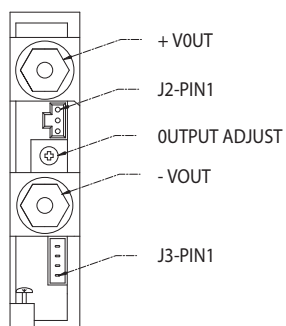

J2 (REMOTE SENSE)

1	TRIM PIN ACCESS
2	+ SENSE
3	- SENSE

MATING HDWR:

HOUSING- MOLEX P/N: 50-57-9403
 TERMINALS- MOLEX P/N: 16-02-0103
 CRIMP TOOL MOLEX P/N: 11-01-0208

J3 DC OK (POWER GOOD)

4	Vcc IN
3	POWER GOOD
2	POWER GOOD INVERTED
1	SIGNAL GROUND

MATING HDWR:

HOUSING- MOLEX P/N: 39-01-0043
 TERMINALS- MOLEX P/N: 30-00-0031
 CRIMP TOOL MOLEX P/N: 57005-5000

DualPAC

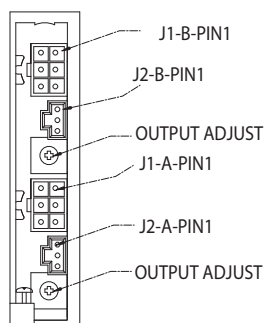

J1 (OUTPUT CONNECTORS)

4	1	1 AND 4 +V OUT
5	2	2 AND 5 -V OUT
6	3	3 +R/SENSE 6 -R/SENSE

MATING HDWR:

HOUSING- MOLEX P/N: 39-01-2060
 TERMINALS- MOLEX P/N: 39-00-0039
 CRIMP TOOL MOLEX P/N: 11-01-0197

J2 (REMOTE SENSE)

1	TRIM PIN ACCESS
2	+ SENSE
3	- SENSE

MATING HDWR:

HOUSING- MOLEX P/N: 50-57-9403
 TERMINALS- MOLEX P/N: 16-02-0103
 CRIMP TOOL MOLEX P/N: 11-01-0208

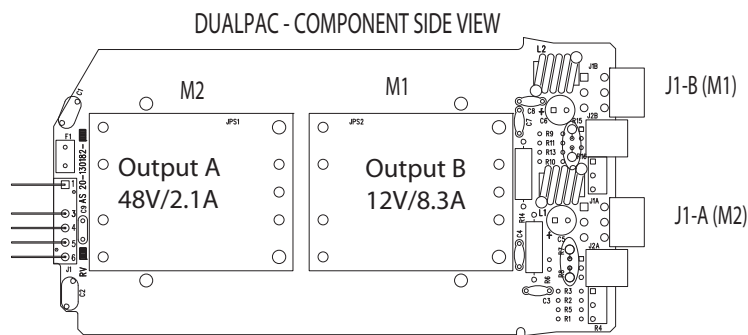

Example: D12V/8.3A-48V/2.1A

ConverterPAC Output and Connector Pin Identification for the 3 Phase/4kW MegaPACs

BatPAC

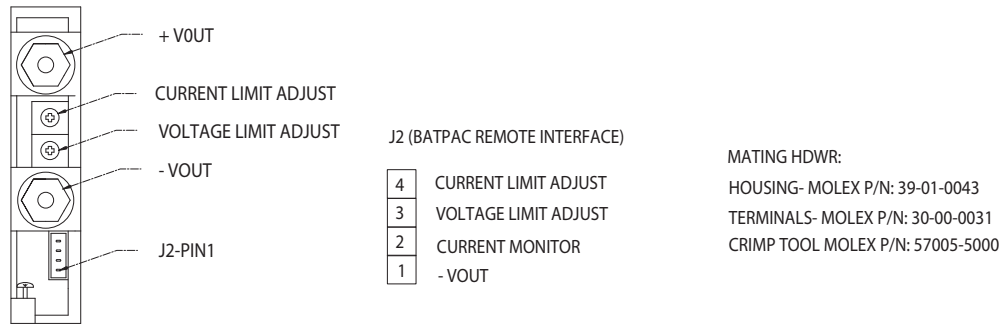

UniPAC

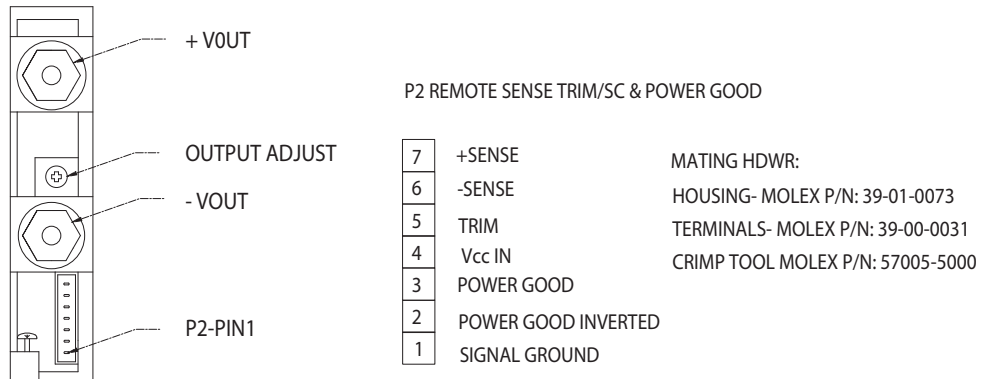

Note: The UniPAC can ONLY be used in the 4kW MegaPAC.

Part Numbering

3Ø MegaPAC **MPx₁-5x₂xxxx**
 eg. MP4-510108

x_A Number of outputs
x_B Number of modules
5 3 Phase MegaPAC chassis
xxxx Assigned by Westcor

4kW MegaPAC **MPx₁-4x₂xxxx-x₃x₄-x₅.x₆**
 With VI-200/VI-J00 eg. MP10-410008-23
 With Maxi eg. MX10-410008-23

x₁ Number of outputs
x₂ Number of modules
4 4kW MegaPAC chassis
x₃ Optional Code
 2 = VI-J00 or VI-200 module in slot #1; 3 = Maxi in Slot 1
x₄ Optional Code
 2 = VI-J00 or VI-200 module in slot #10; 3 = Maxi in Slot 10
xxxx Assigned by Westcor
x₅ Optional Code
x₆ Optional Code

* If a Maxi module is used, the part number changes from MP to MX.

ConverterPAC **Xx_DV/x_EAx_F**
 eg. M15V/10A
 M15V/10ADF
 D15V/6.7A-12V/8.3AT

X ConverterPAC type
 M - ModuPAC
 D - DualPAC
 J - JuniorPAC
 R - RAMPAC
 B - BatPAC
 XU - UniPAC (currently only used in the 4kW MegaPAC)

x_D Voltage out
x_E Current out (rounded to 1 decimal point)
x_F Options (See below*). Can be multiple options.

*ConverterPAC Options

B	Booster module (S1 for FasTrak)	M	M-Grade module
D	DC OK or Power Good ¹	P	Preload
F	Full 50-110% output adjustment	R	RAM external ³
F1	50-107.5% output adjustment ²	S	Trimpot removed for external BatPAC adjustment
F2	50-105% output adjustment	T	90-110% output adjustment ⁴
F3	50-102.5% output adjustment	T1	90-107.5% output adjustment
F4	50-100% output adjustment	T2	90-105% output adjustment
F5	60-110% output adjustment	T3	90-102.5% output adjustment
F6	70-110% output adjustment	T4	90-100% output adjustment
F7	80-110% output adjustment	T5	98-105% output adjustment
F8	90-110% output adjustment	T6	100-110% output adjustment
F9	100-110% output adjustment	V1	"VXI" low noise (150 mV) 15V < Vout ≤ 24V outputs ⁵
I/H	I-/H- Grade module	V2	"VXI" low noise (50 mV) Vout ≤ 15 Vdc
K	Custom SRF module used	V3	1% ripple Vout >24V

¹ **D option:** Optional for all ConverterPACs EXCEPT the DualPAC, BatPAC

² **F options:** Optional for all ConverterPACs EXCEPT the BatPAC and DualQPAC

³ **Ram:** When using an external RAM, components such as autosense resistors and local sense jumpers must be removed before turning on the supply. In addition, in order to insure proper operation, sense pins must be connected either locally or remotely after the RAM's output. For further information, contact Applications Engineering.

⁴ **T options:** Optional for all ConverterPACs EXCEPT the BatPAC and DualQPAC

⁵ **V options:** Optional ONLY on the ModuPAC, DualPAC and JuniorPAC. N/A on all other ConverterPACs.

3 Phase and 4kW MegaPACs “Quick Install” Instructions (For Mechanical Drawing, see page 13 & 14)

Mounting the 3 Phase MegaPAC and 4kW MegaPAC

- * The 3 Phase MegaPAC and 4kW MegaPAC can be mounted on any of four sides.
- * Use #8-32 or 4mm mounting screws. Maximum penetration should not exceed 0.15" (3,8mm).
- * **A minimum of 2" (5,1cm) clearance must be maintained at either end of the supply in order to insure proper airflow and cooling.**
- * Maximum allowable torque is 20 lb-in.

Input Connections

Input Power J1

- * Input AC power is applied to terminal block J1 using mating receptacle AMP #54483-4 with #53892-4 crimp or #54329-1 solder terminals provided.
- * Use size 12 AWG wire with soldered terminals.
- * A fuse or circuit breaker in the input line is required for safety reasons.

Input Panel Connectors

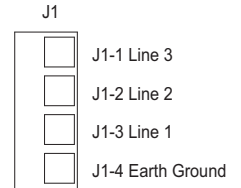

Output Connections

Power Connections

Installing ring lugs and/or bus bars on output studs:

- * The upper stud is Positive and the lower stud is the Return.
- * Remove outer nut. **Do not remove or loosen inner nut.**
- * Place ring lug over output stud.
- * Replace and tighten outer nut to a maximum torque of **45 lb-in. Do Not Over-Tighten Nuts.**
- * **Verify all output nuts are properly installed before turning on supply.**

Installing power connectors on DualPACs (J1A and J1B):

- * Use Molex mating receptacle #39-01-2060 with #39-00-0039 terminals provided.
- * Pins 1 and 4 are Positive, while pins 2 and 5 are the Return.
- * Attach terminals to 18-24 AWG stranded wire using Molex tool #11-01-0197.

Single Output ModuPAC

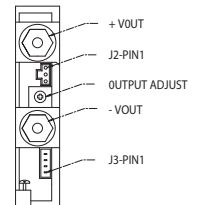

DualPAC Output Connectors

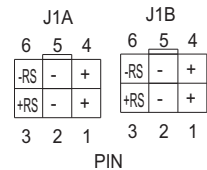

- PIN
- 1 & 4 +V OUT
 - 2 & 5 -V OUT
 - 3 +REMOTE SENSE
 - 6 -REMOTE SENSE

Sense Connections

Note: Newer power supplies may have a new feature installed called Autosense. For units with Autosense, if Remote Sense connections are not made or needed, no Local Sense selection is necessary - simply connect the output to the load and the unit will automatically operate in Local Sense. If Remote Sense connections are made, the unit will operate in a Remote Sense mode. Remote Sense terminals should be terminated to their respective output i.e. - RS to - Output and + RS to + Output. See page 15 for more information on Autosense.

For units without Autosense, sense connections must always be made. Not connecting Sense lines to their respective outputs can cause failure to the unit.

Sense Connector J2 (P2 for the UniPAC):

- * Sense connections do not have to be made if the Local Sense option has been ordered. (An “L” in the ConverterPAC part number means the Local Sense option has been installed; e.g. M5V/40AL. Only applies to units without Autosense.)
- * Use Molex mating receptacle #50-57-9403 with #16-02-0103 terminals provided.
- * J2-2 is the +Sense and J2-3 is the -Sense.
- * Attach terminals to 22-24 AWG twisted pair wire using Molex tool #11-01-0208.
- * Attach opposite ends of Sense lines to point where regulation is desired.
- * **Verify that Sense lines are not cross-connected before applying input power.**
- * For the UniPAC, P2-7 is the + Sense and P2-6 is the -Sense.
- * Use Molex mating receptacle #39-01-0073 with #39-00-0031 terminals provided
- * Attach terminals to 22-28 AWG stranded wire using Molex tool #57005-5000.

J2 Sense Connectors

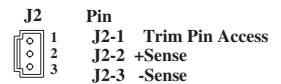

P2 REMOTE SENSE, TRIM/SC & POWER GOOD

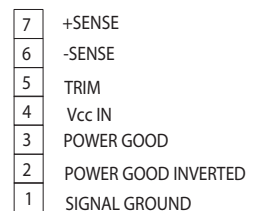

Sense Connections on DualPACs:

- * Sense connections do not have to be made if the Local Sense option has been ordered. (An “L” in the ConverterPAC part number means the Local Sense option has been installed; e.g. D5V/20AL-12V/4.2AL. Only applies to units without Autosense.)
- * Sense connections are available on the J2, P2 or the J1A and J1B connectors.
- * If using J2 or P2 connectors, see page 11.
- * For J1A and J1B, Pin 3 is the +Sense and Pin 6 is the -Sense.
- * Use Molex mating receptacle #39-01-2060 with #39-00-0039 terminals provided.
- * Attach terminals to 18-24 AWG twisted pair wire using Molex tool #11-01-0197.
- * **Verify that Sense lines are not cross-connected before applying input power.**

DualPAC Output Connectors

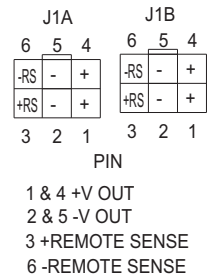

J2 Trim Connection (and P2 for UniPACs)

- * The J2 remote Trim connection should only be used if the local Trim option has not been installed. (A “T” or an “F” in the ConverterPAC part number means the Trim option is installed; e.g. M5V/40AT.)
- * Use Molex mating receptacle #50-57-9403 with #16-02-0103 terminals provided and 22-24 AWG stranded wire using Molex tool 11-01-0208.
- * J2-1 provides Trim access.
- * For the UniPAC, refer to P2 Connector. P2-5 provides Trim Access.
- * Use Molex mating receptacle #39-01-0073 with #39-00-0031 terminals provided.
- * Attach terminals to 22-28 AWG stranded wire using Molex tool #57005-5000.

J2 Connectors

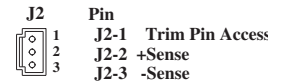

DC OK (Power Good)

- * DC OK is only available as an option and is only present when requested.
- * Use Molex mating receptacle #39-01-0043 with #39-00-0031 terminals provided.
- * Attach terminals to 22-28 AWG stranded wire using Molex tool #57005-5000.
- * For the UniPAC, refer to the P2 Connector. P2-3 is Power Good.
- * Use Molex mating receptacle #39-01-0073 with #39-00-0031 terminals provided.
- * Attach terminals to 22-28 AWG stranded wire using Molex tool #57005-5000.

J3 Connector

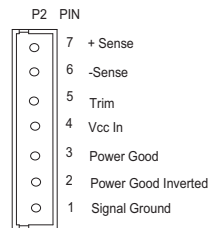
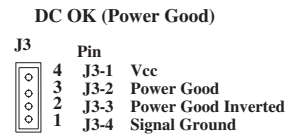

Interface Connections J10

- * J10-7 to 11 and J10-20 to 24 are Enable/Disable for slots 1-10.
- * J10-16, 17 are Vcc, J10-12 and 15 are Signal Ground, J10-18 is AC Power OK, and J10-5 is General Shutdown.

J10 INTERFACE CONNECTOR IDENTIFICATION

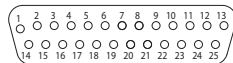

1	Signal Ground	14	Phase Fail
2	Signal Ground	15	Signal Ground
3	Overtemperature Warning	16	Vcc +5 volt, 300 mA
4	Analog Temperature	17	Vcc +5 volt, 300 mA
5	General Shutdown	18	A.C. Power OK
6	No Connection	19	A.C. Power Fail
7	Enable/Disable # 10	20	Enable/Disable # 9
8	Enable/Disable # 8	21	Enable/Disable # 7
9	Enable/Disable # 6	22	Enable/Disable # 5
10	Enable/Disable # 4	23	Enable/Disable # 3
11	Enable/Disable # 2	24	Enable/Disable # 1
12	Signal Ground	25	Gate # 10 (Output (Isolated))
13	Gate # 1 Input (Isolated)		

3 Phase MegaPAC Mechanical Drawings

FRONT VIEW

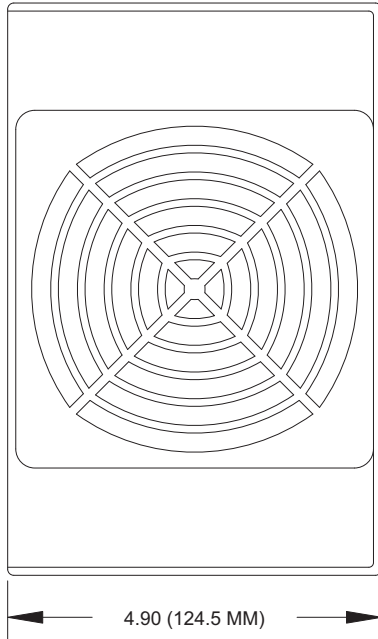

REAR VIEW

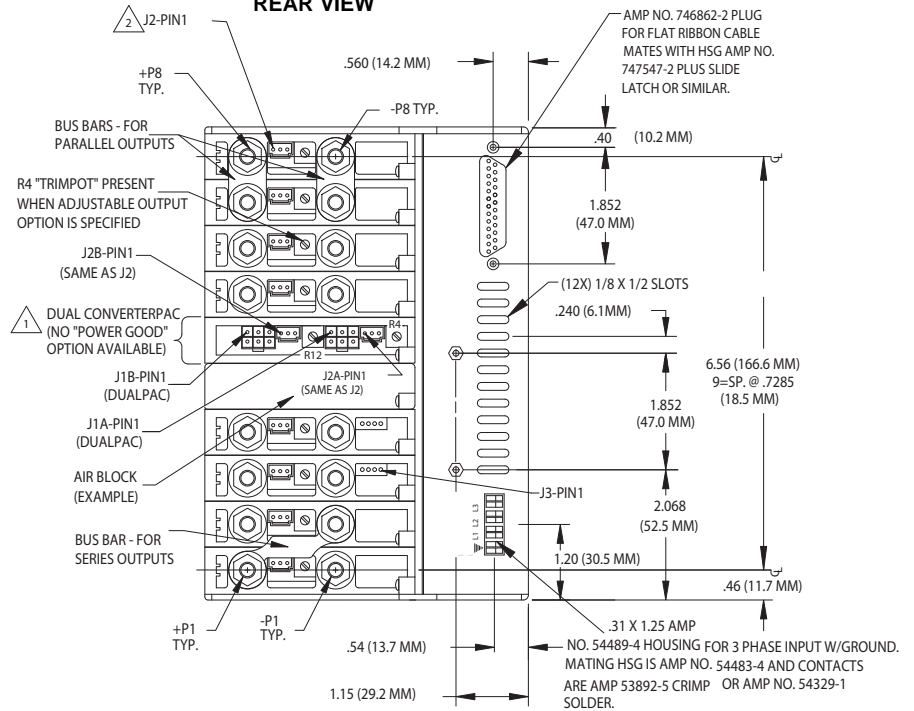

TOP AND SIDE VIEW

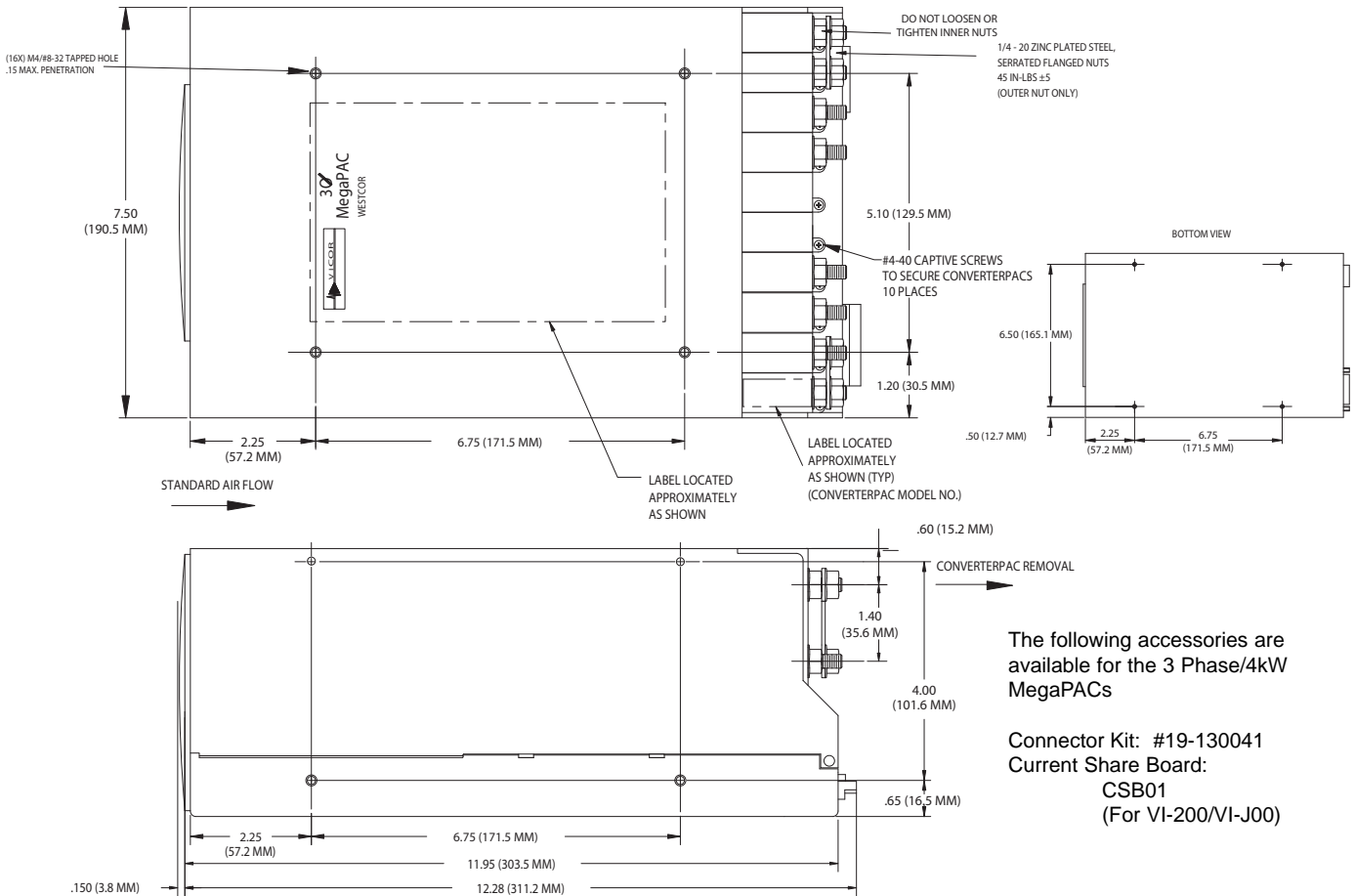

The following accessories are available for the 3 Phase/4kW MegaPACs

Connector Kit: #19-130041
 Current Share Board:
 CSB01
 (For VI-200/VI-J00)

Interface Connections

Chassis Input Power Terminals (J1)

Input AC power is applied to a plug-in connector, J1, that accepts soldered terminals with a wire size of 12 AWG. For operation on high voltage DC input, input power can be connected to any two input lines. A fault-clearing device should be installed at the input of the unit. A user-accessible input fuse is not present within the unit. For an output of 2,000-4,000W with operation on 208 Vac, 3Ø input, a 20A fuse in each input line is acceptable. Input power cables should be shielded to minimize radiated noise effects.

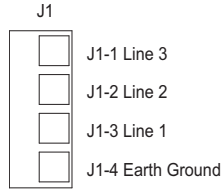

Figure 3. Input Panel Connector

Output Power Connections (+P, -P for Single Output, or J1A/J1B for Dual Outputs)

For single output ConverterPACs, these terminals are two 1/4-20 plated steel studs. The upper stud is positive with respect to the lower stud. For dual output ConverterPACs, there is a 6-pin Molex connector for each output. J1A pins 1 and 4 are the +Output, and J1A pins 2 and 5 are the -Output. Pins 3 and 6 are duplicates of the Remote Sense terminals present on J1B. Use appropriate wire size rated to handle the full output current, including short circuit levels. Avoid large current loops in output cables; run power and return cables next to one another to minimize inductive effects. All outputs are isolated and can provide positive or negative outputs.

Output +/-Sense Connections (J2 for Single Output, or J1A/J1B for Dual Outputs)

Newer power supplies may have some outputs configured with the Autosense feature that automatically locally senses the output if remote sense is not used. To check if an output has the Autosense feature, measure the impedance from the + Out to + Sense and - Out to - Sense pins. If the impedance is 5 ohms, then the output has Autosense and does not require local sense jumpers.

For units without Autosense, sense connections must be made. When making sense connections, keep in mind that although all outputs are open-Sense protected, the +/-Sense terminals **MUST** be connected to their respective outputs before the 3 Phase MegaPAC or 4kW MegaPAC is powered up. Regardless of the output polarity configured, the +Sense should always connect to the +Power output. The -Sense connects to the -Power output. Sense connections are not required on booster ConverterPACs, BatPACs, or if the Local Sense option is specified.

Signal Ground (J10-1, J10-2, J10-12, J10-15)

Signal Ground (see Figure 4) is an isolated ground reference for all J10 interface signals, and can be used for ConverterPAC output status signals such as Power Good. This is not the same as Earth Ground on input power connector J1.

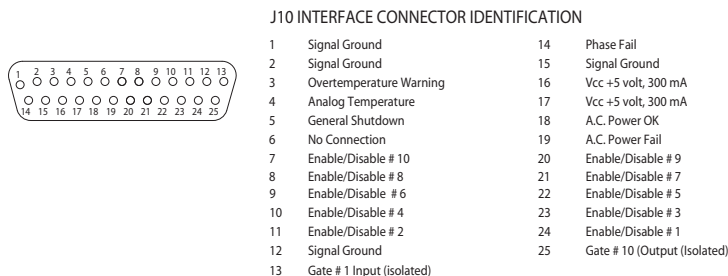

Figure 4. Interface Connector (J10)

Enable/Disable and General Shutdown (GSD)

The Enable/Disable control lines allow ConverterPAC outputs to be sequenced either on or off. For DualPACs, both outputs are sequenced. In parallel arrays, only the driver ConverterPAC needs to be sequenced. The GSD control line on J10-5 allows simultaneous shutdown of all ConverterPAC outputs. An internal factory-configured jumper selects polarity, either active-high or active-low. Another jumper selects a pull-up or pull-down source for the HCMOS control inputs.

The Enable/Disable controls are configured as active-low with internal pull-up; outputs are enabled when these pins are open-circuited or allowed to exceed 4.5V with respect to Signal Ground. Outputs are disabled when the Enable/Disable control lines are pulled low to less than 0.7V. The GSD control line is configured to be active-low with internal pull-up; all outputs are simultaneously inhibited when the GSD control line is pulled low to less than 0.7V. All outputs are enabled when GSD is open circuited or allowed to exceed 4.5V. Do not apply more than 5V to these inputs at any time. The E/D and GSD circuits will sink up to 0.6 mA. If driven from an electromechanical switch or relay, a small capacitor should be connected between the control line and Signal Ground to eliminate latch-up due to the effects of switch bounce (1µF, typical).

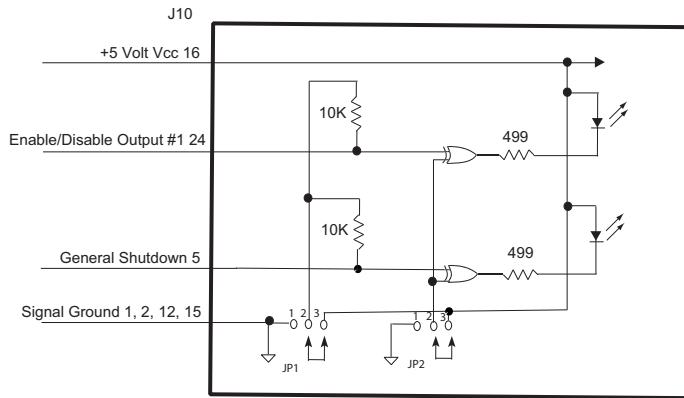

Figure 5. Enable/Disable and General Shutdown

Enable/Disable Control of Maxi Module Arrays

When using the Enable/Disable function on an output that consists of two or more Maxi modules, it is necessary to connect the E/D pins of the corresponding module locations together such that both modules are commanded to turn ON or OFF simultaneously.

Example: Slots 1 through 6 have been configured as a single output parallel array (see Fig. 6)

In order to disable this array, E/Ds 1 through 6 should be shorted together as shown in Fig. 6. With the E/Ds connected together, a single switch can then be used to remotely enable and disable the output.

**Note: For single output power supply configurations, the simplest method of remotely enabling and disabling the output is to use the General Shutdown (GSD) function.



Figure 6. Enable/Disable Control of Maxi Arrays

part number will identify whether slot #1 and slot #10 were configured for use with VI-200/VI-J00 or Maxi ConverterPACs.

Using the example of MX7-410108-32, the last two digits, "-32," identify the type of module in slot #1 and slot #10, respectively. A "3" indicates the chassis is configured to parallel box-to-box using a Maxi converter. A "2" indicates the chassis is configured to parallel box-to-box using a VI-200 converter. The above example shows the chassis is configured for a Maxi converter in slot #1 and a VI-200 converter in slot #10.

When connecting multiple chassis in parallel, the signal ground on J10 of each chassis should be tied together. Chassis outputs should be tied together near the power supply and then cabled to the load. Using separate cables to provide power to the load will limit the supplies' ability to current share properly.

Auxiliary Vcc +5V/0.3A (J10-16, 17)

The Vcc on J10-16, 17 is an auxiliary 5V regulated power source (see Figure 8 and Connector Pin Identification of page 8). It is +5Vdc +/-5% with respect to Signal Ground and can supply 300 mA maximum. It is short-circuit-proof, but if shorted all outputs will shut down through the Enable/Disable circuitry. The Auxiliary Vcc typically powers user circuitry or is used with the Power Good circuitry to provide a pull-up reference for the outputs of the DC Power Good circuit on a ConverterPAC. If used for this purpose, a J10 Signal Ground must also be connected to the J3-1 Signal Ground pin of the ConverterPAC.

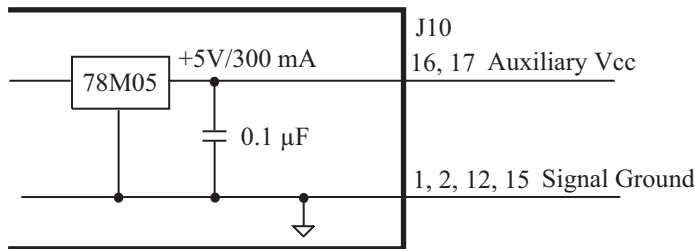

Figure 8. Auxiliary Vcc

Power Good (J3-3)

The optional Power Good signal on J3-3 is referenced to Signal Ground on J3-1, and indicates the status of the output voltage. This signal is asserted a TTL "1" when the output voltage is above 95% of nominal. It is a TTL "0" when the output voltage is below 85% of nominal.

If the Trim option is also used, the Power Good trip points DO NOT track with the trimmed voltage. It is possible to trim the output below the fixed setpoints of the Power Good circuit and cause a negative Power Good signal.

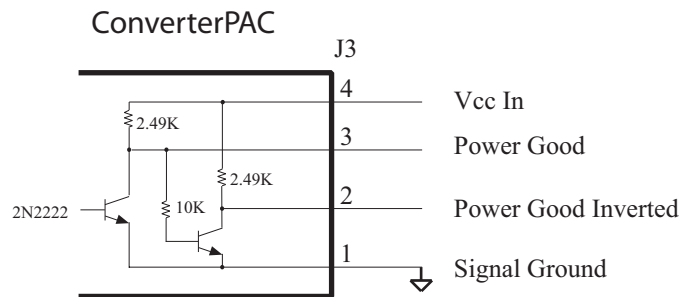

Figure 9. Power Good and Vcc

Power Good Inverted (J3-2)

This is the inverse of the Power Good signal and is referenced to Signal Ground on J3-1.

Signal Ground (J3-1)

Signal Ground on J3-1 is an isolated secondary ground reference for J3 status signals. It is used to provide a reference point for the Power Good circuitry and is not the same as Earth Ground on input power connector J1.

Vcc In (J3-4)

The Vcc In on J3-4 is an input that requires +5V either from the J10 Auxiliary Vcc, or from another source. Input current to this pin is limited by an internal resistor to 3 mA. If the J10 Auxiliary Vcc is connected to Vcc In on J3-4, then at least one J10 Signal Ground must be connected to Signal Ground on J3-1.

+Sense/-Sense (J2-2 and J2-3)

The +Sense on J2-2 should be connected to the +Power Out, and the -Sense on J2-3 to the -Power Out terminal. **Do not reverse or leave the Sense pins open.** Sense pins can be terminated locally at the output of the power supply, in which case the power supply will provide regulation at the output terminals. The voltage appearing at the load may drop slightly due to voltage drop in the power cables. If it is necessary to compensate for voltage drop along the output power cables, this termination should be made close to the output load. Compensation of up to 0.5V (0.25V per lead) can be obtained. Use twisted pair 22-24 AWG wire for this purpose.

Reminder: Only units with Autosense will automatically operate in Local Sense mode if no sense connections are made. It will operate in remote sense mode if remote sense connections are made. Units without Autosense MUST have sense connections (Local or Remote) terminated to their respective output for the unit to operate properly.

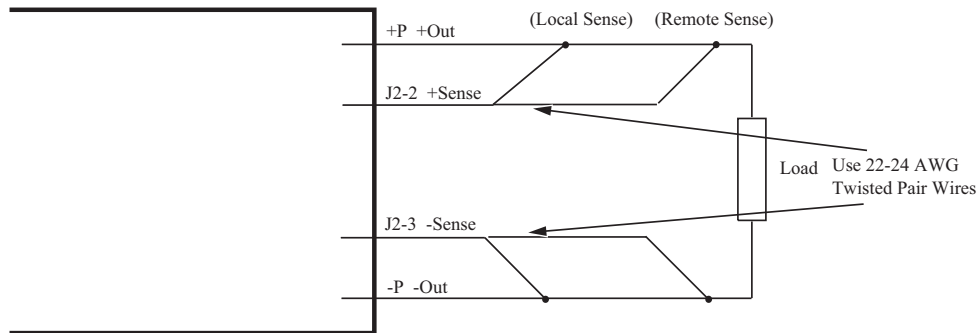

Figure 10. Sense Leads

External Trim (J2-1)

Output voltage can be trimmed using an optional factory-installed Trim potentiometer or with the Trim pin (see Figure 11). The Trim potentiometer is located on the ConverterPAC. If the Trim potentiometer has not been ordered, the Trim pin must be used. When using the Trim pin, the Trim limits are determined by the DC to DC converter used on the ConverterPAC. Maximum Trim ranges are 10% above the nominal converter voltage and 50% below the nominal converter voltage (except 10V, 12V and 15V outputs which are 10% below nominal) as measured from the output studs or output connector of the power supply.

Note: The combined effects of module trim up, remote sense and dynamic load step may cause the module to trip OVP. (See page 7 for information on restart).

The Trim pin on J2 can be used to control the output voltage. It is referenced to the -Sense pin on J2 and can be controlled by either a resistor network or an external voltage source. To increase an output voltage above its nominal, it is necessary to increase the voltage at the Trim pin above the internal reference voltage (V_{ref}). The reverse is true to decrease an output voltage.

Note: Converters are sometimes pretrimmed at the factory if a nonstandard output voltage is requested. Standard voltages include 2V, 3.3V, 5V, 10V, 12V, 15V, 24V, 28V, and 48V. If using a nonstandard voltage, or if a ConverterPAC is ordered with a Trim option, the resistor calculations will differ from those below. Please consult the factory for assistance.

OUTPUT MODULE	V_{ref}	R_{TH}
VI-200/VI-J00 $\geq 3.3V$	2.5 V	10.0 k Ω
VI-200/VI-J00 $< 3.3V$	0.97V	3.88k Ω
Maxi (Pre-Defined)	1.23V	1.0 k Ω
Maxi (User Defined)	1.23V	Consult Factory

Table 1. Module Internal Reference Voltages and Thevenin Resistances.

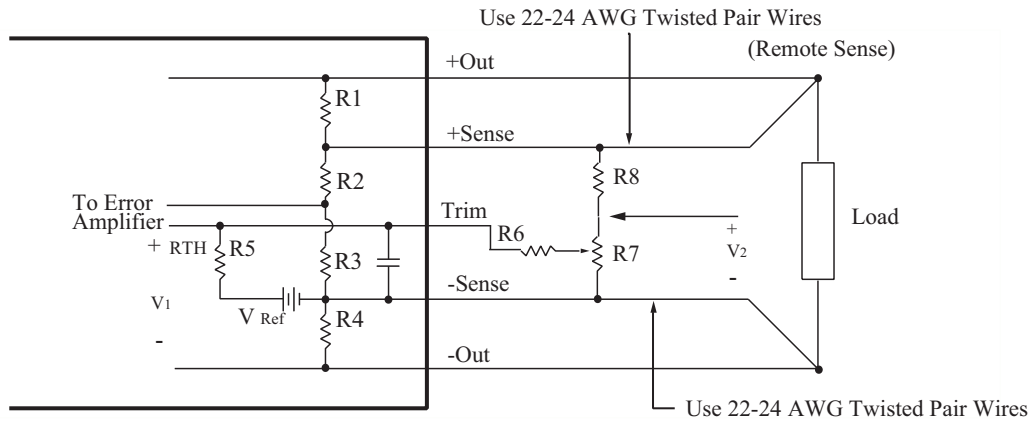

Figure 11. External Trim

Example:

±10% Trim adjust on a 12V nominal output.

Figure 11 shows a typical variable Trim circuit. Using a 10k trimpot (R7), the resistor values for R6 and R8 can be calculated as follows:

$$V_1 = V_{ref} + 10\% = 2.75V$$

$$\text{Given: } V_{ref} = 2.5V \text{ (see Table 1)}$$

$$I_{R5} = (2.75V - V_{ref})/R_{TH} = (2.75V - 2.5V)/10k\Omega = 25\mu A$$

Setting the bottom limit:

$$V_{R6} = 2.5V - 10\% = 2.25V$$

And since $I_{R5} = I_{R6} = 25\mu A$,

$$R6 = V_{R6}/I_{R6} = 2.25V/25\mu A = \underline{90k\Omega}$$

$$V_2 = V_1 + V_{R6} = 2.75V + 2.25V = 5V$$

$$I_{R7} = V_2/R7 = 5V/10k\Omega = 500\mu A$$

$$I_{R8} = I_{R7} + I_{R6} = 525\mu A$$

$$V_{R8} = (V_{nom} + 10\%) - V_2 = 13.2V - 5V = 8.2V$$

$$\text{Given: } V_{nom} = 12V$$

$$R8 = V_{R8}/I_{R8} = 8.2V/525\mu A = \underline{15.62k\Omega}$$

Using the above resistor combination, a 12V output can be trimmed externally up to 13.2V and down to 10.8V. For further information on external trimming, refer to Chapter 5 of the Applications Manual or consult the factory for assistance.

CONSULT APPLICATIONS ENGINEERING WHEN TRIMMING OUTPUTS BELOW 5V.

Specifications

Input Characteristics

Input Voltage	3 \emptyset 208/240 Vac, 1 \emptyset 180-264 Vac, (47-500Hz) 260-352 Vdc
Power Factor (passive)	0.92 (3 Phase operation)
Inrush Current	30A rms @ 230 Vac
Ride Through Time	>20 ms at nominal line, full load
Power Fail	>3 ms warning
Conducted EMI 47 - 63 Hz	EN 55022 Level A
Surge Immunity (Common Mode and Normal Mode)	EN 61000-4-5 Class 3 (Temporary loss of output power may occur which is self recoverable)
Dielectric Withstand	Primary to Chassis GND = 2,121 Vdc Primary to Secondary = 4,242 Vdc Secondary to Chassis GND = 750 Vdc

Output Characteristics

VI-200/VI-J00 Line/Load Regulation	0.2% max. from 10% to 100% load; 0.5% max. from 0% to 10% load
Maxi Line Regulation*	0.20% max to 0.30% max
Maxi Load Regulation*	0.20% max to 0.70% max
VI-200/VI-J00 Setpoint Accuracy*	1% for standard voltages; 2% for special or adjustable voltages
Maxi Setpoint Accuracy	1% for standard voltages; 2% for special, adjustable voltages and 48 Vdc outputs
Ripple and Noise	Std. outputs: 2% or 100 mV p-p max., whichever is greater, 10% min. load VXI options: 50 mV p-p \leq 15 Vdc; 150 mV p-p max. for >15V \leq 24 1% ripple for > 24V; RAMPAC: 10mV p-p max. or 0.15% whichever is greater UniPAC: see Vicor module specifications
Output Trim Range	10% -110% of nominal voltage Maxi modules 50% -110% of nominal voltage VI-200/VI-J00 modules 90% -110% of nominal voltage VI-200/VI-J00 modules 10-15V
Overcurrent Trip Point	105-125% of full load capability of VI-200/VI-J00 modules 115% typical of full load capability of Maxi modules
Overvoltage Protection	ModuPACs: 115-135%
Efficiency	82% typical
Output Power: 4kW MegaPAC 3 Phase MegaPAC	4,000W at 45°C (3 Phase); 1,500W at 45°C (1 Phase) 2,000W at 45°C (3 Phase); 1,200W at 45°C (1 Phase)

Environmental Characteristics

Storage Temperature	-40°C to 85°C
Operating Temperature*	-20°C to +45°C full power, -20°C to +65°C half power
Humidity	0 to 95% non-condensing
Altitude	Derate 2.6% total output power for each 1,000 ft to a maximum operating altitude of 15,000 ft. Non-operating storage maximum altitude is 40K

Specifications (continued)

Safety Approvals cURus – UL 60950-1, CSA 60950-1
 cTUVus – EN 60950-1, UL 60950-1, CSA 60950-1
 CE Mark – Low Voltage Directive, 73/23/EEC amended by 93/68/EEC

Product Weights **3 Phase MegaPAC:** 18.1lbs (8.21kgs) fully configured.
 4KW MegaPAC: 21.5lbs (9.77 kgs) fully configured

Warranty 2 years limited warranty.
 See vicorpower.com for complete warranty statement.

**** See Vicor module specifications. A preload may be necessary for modules trimmed down below 90% of normal output voltage.**

****Note: Operating temperature is 45°C using any combination of modules and output voltages as long as the front end rating is not exceeded. Normal derating applies to half power if the ambient temperature is 20°C hotter.**

CURRENT SHARE BOARD - Optional Feature

"Current sharing" also known as Load Sharing, is the ability to divide the output current evenly across all active power supplies. This greatly reduces stresses on each power supply and allows them to run cooler, resulting in higher reliability. Standard "current sharing" techniques typically utilize shunt resistors or Hall Effect devices to measure the current from each power supply. Power shunt resistors continually dissipate power and require cooling especially when dealing with high output currents of >100Amps. Hall Effect devices measure magnetic fields generated by current flowing through a conductor and, although they dissipate no power, they tend to be large and expensive.

First developed by Westcor Engineering for paralleling MegaPAC supplies, the Box-to-Box Current Share Board or CSB allows two or more Vicor power supplies to current share by utilizing the inherent voltage drop produced in the negative output return cable. This eliminates the need for additional shunt resistors or expensive Hall Effect devices and provides a simple 5 wire connection method to achieve a +/-1mV accuracy between the Negative Output power rails. This accuracy translates to a 1% current sharing if there is a total of 100mV conduction voltage drop in the negative return path.

Constructed as a current source to drive the Trim pin of a Vicor module, the design uses an accurate comparator circuit to monitor the power returns. In addition, the circuit is unidirectional and can only trim an output voltage up. The benefit is that only the supply that is supporting less current is adjusted up. This action balances the currents to the load by matching the output voltages of the supplies. In the case of one supply failing, the circuit will attempt to trim the failed supply only. This will leave the remaining functional supply alone to provide power to the load at its nominal voltage. Thus the circuit also offers simple redundancy. In addition, because CSB functions as a current source, the Trim outputs (T1 and T2) of the CSB can be placed in parallel to create a summing node. This allows current sharing between more than two supplies by paralleling the T2 output of one CSB circuit with the T1 output of the next CSB.

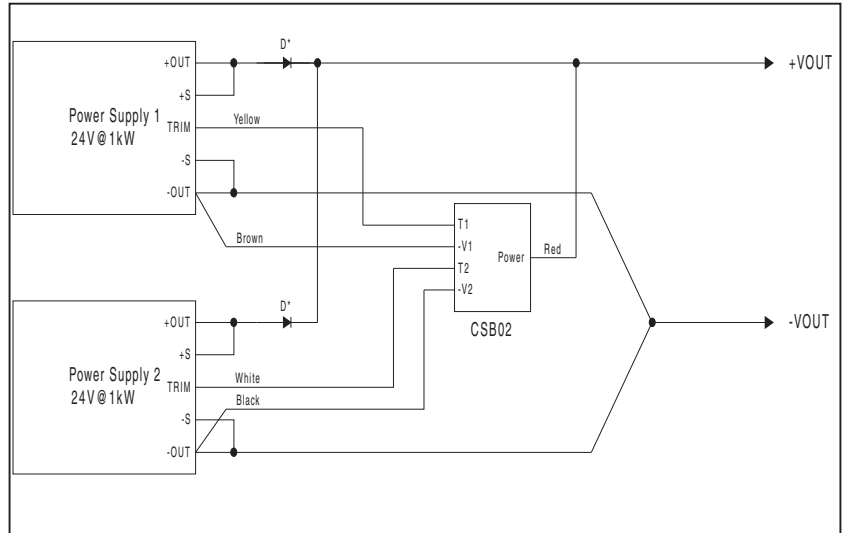

Figure 1. CSB Interconnect Example

Please note: The CSB is not intended for use in Hotswap Applications.

Requirements:

1. For proper operation, the power supplies being paralleled should be enabled at the same time.
2. -Out conductors must be of equal length and wire gauge. Separate -Out conductors must be used from each supply to the load, or the use of a "Y" connection to a common point must be used as shown in figure 1. Each leg of the "Y" must have a minimum of a few millivolts of drop in order for proper operation. 50mV to 100mV of drop will provide from 5% to 1% accuracy.
3. -V1 and -V2 for all Box-to-Box circuits must be connected directly at the negative output power studs or terminals to achieve accurate current sharing.
4. D* can be added if redundancy is needed. If redundancy is not required, D* can be replaced with direct wire connections.
5. When using D*, the Power input should be connected on the cathode side of the paralleling diodes as shown above.
6. Terminate Sense Leads either locally or remotely as shown in figure 1.
7. For paralleling more than 2 supplies consult factory for assistance.

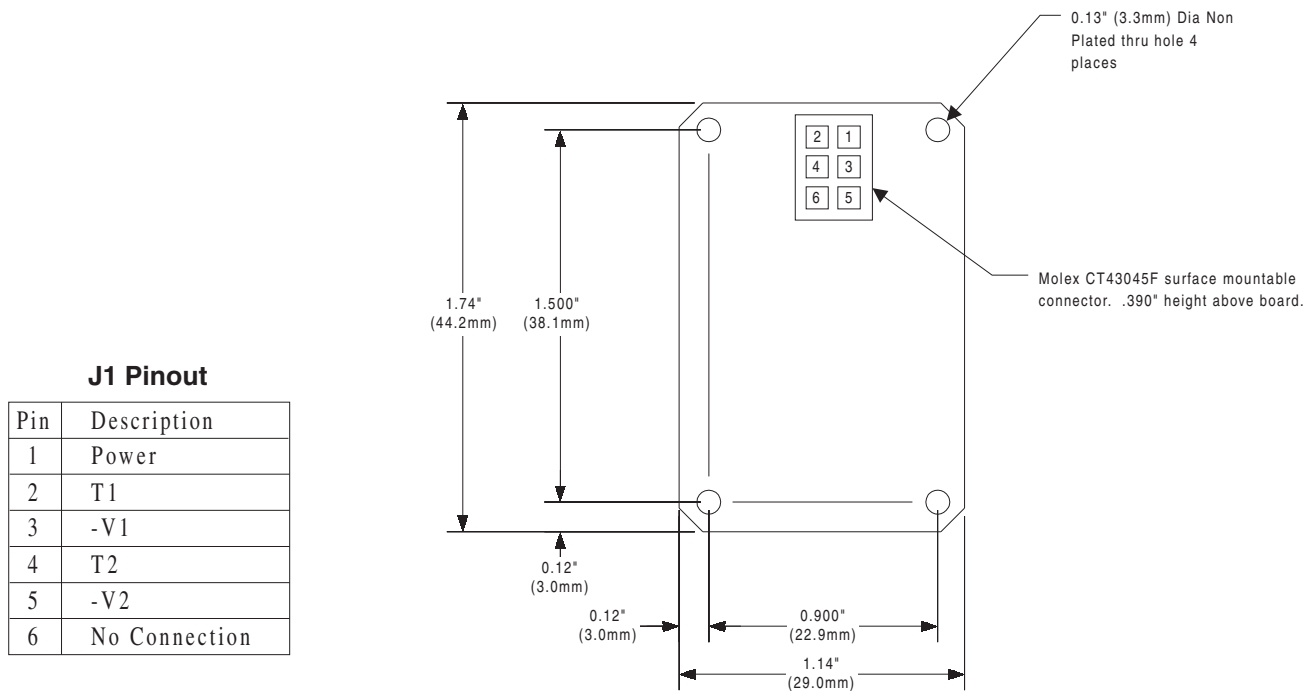

Figure 2. Mechanical Drawing



Figure 3. Cable Drawing

Specifications:

1. Power: 2-50Vdc at 5mA maximum.
2. Accuracy: +/- 1mV between -Vout connections.
3. Output current when not trimming up: +/- 1uA (VI-200/J00), +/-5uA (Maxi).
4. Use 4 non-plated through holes with standoffs for mounting.
5. CSB01 MUST be used for current sharing VI-200/VI-J00 converters .
6. CSB02 MUST be used for current sharing Maxi converters

*****PLEASE NOTE, THE CSB IS NOT INTENDED FOR HOTSWAP APPLICATIONS*****

Contact your Regional Applications Engineer at 1-800-927-9474 for additional information.

LOW LEAKAGE VERSION (Available upon request)

If Low Leakage is required, the MegaPAC Family of Power Supplies has a model variant (must be requested). This model enables the user to meet various additional specifications. Presently, the PFC MegaPAC, Mini MegaPAC and Autoranging MegaPAC are available in Low Leakage versions. Other models can be made available. The MegaPAC Family of Power Supplies consist of:

- PFC MegaPAC
- PFC MegaPAC-High Power
- PFC MegaPAC-EL (Low Noise)
- Mini MegaPAC
- Autoranging MegaPAC
- 4kW MegaPAC
- 4kW MegaPAC-EL (Low Noise)

The advantage of the Low Leakage MegaPAC power supply is in multiple power supply systems that have one AC input. This option will lower the input leakage current for these products to 100 μ A or less. An additional external EMI filter is typically required.

How Low Leakage is obtained

Low Leakage for the MegaPAC Family of power supplies is obtained with the removal of the "Y" capacitors from within the EMI filter of the MegaPAC as well as the "Y" capacitors on the input of the ConverterPACs*. This reduces the leakage current from the AC input to AC ground (chassis) to below 100 μ A. At the same time, since the "Y" capacitors are a vital component of the EMI filter, without them, the EMI will go up. When this happens, the unit will no longer meet Westcor's published specifications for conducted EMI. In order to reduce the EMI to within an acceptable limit, an additional external EMI filter is required. All safety agency certifications for the MegaPAC Power Supplies remain intact. Contact Applications Engineering for more information.

* Westcor currently has the following ConverterPACs (See ConverterPAC datasheet and/or Design Guide for more information):

VI-200/VI-J00

Maxi

ModuPAC (M)
 JuniorPAC (J)
 DualPAC (D)
 RamPAC (R)
 BatPAC (B)
 QPAC (L)
 DualQPAC (LD)
 Junior QPAC (LJ)

FinPAC (PZ)
 UniPAC (XU)
 QPAC (XQ)

** Please note that the MegaPACs (including the Low Leakage versions) are not UL 2601/60601 compliant.

Notes

VICOR GLOBAL OFFICES

USA

**Vicor Corporation,
Corporate Headquarters**
25 Frontage Road
Andover, MA 01810
Tel: 800-735-6200,
Tel: 978-470-2900
Fax: 978-475-6715

Vicor Corporation
377 E. Butterfield Road
Suite 201
Lombard, IL 60148
Tel: 630-769-8780
Fax: 630-769-8782

Vicor, Westcor Division
560 Oakmead Parkway
Sunnyvale, CA 94085
Tel: 408-522-5280
Fax: 408-774-5555

EUROPE

Vicor France
Tel: 33-1-3452-1830
Free Phone
France Only:
0800 419 419
Fax: 33-1-3452-2830
Email: vicorfr@vicr.com

Vicor Italy
Tel: +39-02-2247-2326
Free Phone *Italy Only:*
800-899-677
Fax: +39-02-2247-3166
Email: vicorit@vicr.com

Vicor Germany
Tel: +49-89-962439-0
Free Phone
Germany Only:
0800 018 29 18
Fax: +49-89-962439-39
Email: vicorde@vicr.com

Vicor U.K.
Tel: +44-1276-678-222
Free Phone *UK Only:*
0800-980-8427
Fax: +44-1276-681-269
Email: vicoruk@vicr.com

ASIA-PACIFIC

Vicor Hong Kong
Tel: +852-2956-1782
Fax: +852-2956-0782

Vicor Japan Co., Ltd.
Tel: 81-3-5487-3880
Fax: 81-3-5487-3885

For more information about this or other Vicor products, or for assistance with component-based power system design, contact the Vicor office nearest you. Vicor's comprehensive line of power solutions includes modular, high-density DC-DC converters and accessory components, configurable power supplies, and custom power systems. Westcor, a division of Vicor, designs and builds fan cooled, configurable power supplies incorporating Vicor's high density DC-DC converters and accessory components. Westcor's product line includes:

LOPAC FAMILY:

- PFC MicroS
- PFC Micro
- PFC Mini

MEGAPAC FAMILY:

- PFC MegaPAC
- PFC MegaPAC-EL (Low Noise)
- Mini MegaPAC
- Autoranging MegaPAC
- ConverterPACs
- PFC MegaPAC (High Power)
- 4kW MegaPAC

OTHERS:

- FlatPAC-EN
- PFC FrontEnd

Information furnished by Vicor is believed to be accurate and reliable. However, no responsibility is assumed by Vicor for its use. No license is granted by implication or otherwise under any patent or patent rights of Vicor. Vicor components are not designed to be used in applications, such as life support systems, wherein a failure or malfunction could result in injury or death. All sales are subject to Vicor's Terms and Conditions of Sale, which are available upon request.

Specifications are subject to change without notice. *The latest data is available on the Vicor website at vicorpower.com*



www.vicorpower.com