

# WIDE RANGE TRIMMING WITH VARIABLE LOADS

By Arthur Jordan  
Sr. Application Engineer, Vicor

The Power Bench

## TPB 103

The output of Vicor 2nd Generation DC-DC converter modules can be programmed from 10 to 110% of their nominal output voltage. Trimming down is easily accomplished with a small low power resistor or potentiometer connected between the SC pin and the -S pin as shown in Figure 1.

With a wide trim range, a preload may be needed to maintain a stable trimmed voltage, especially at light loads. A minimum load is often required, for example, when the output is programmed below 75% of nominal, but it is always required if it is trimmed below 25%. Although a resistor can be used to simply provide a minimum load, at voltages above the minimum trim voltage, its dissipation will be increased unnecessarily. In addition, as the system load increases, the preload is no longer needed; it simply wastes power.

Moreover, minimum load requirements change under certain circumstances such as percentage of trim and input line voltage. For example, a typical V48B28C250A (a 36-75V input, 28V at 250W output DC-DC converter module) might require a load of only 0.4A to program its output down to 2.8V with 36Vdc input, while it will need approximately 1.6A of load current when the input voltage is 75Vdc (high line).

Two simple preload circuits are presented that automatically turn on when required and vary in value according to the load on the system.

The preload circuit shown in Figure 1 is suitable for most higher output voltage modules and utilizes a Darlington npn transistor. The circuit functions satisfactorily down to low voltages (2.8V depending on components and conditions) without an auxiliary rail. However, for 48V output modules, a simple auxiliary rail to limit the peak voltage to the OP AMP may be required. Although its ability to trim down the output voltage is limited by the  $V_{ce(sat)}$  of the Darlington, it has the advantage of simplicity.

The second circuit, shown in Figure 2, is more suited for low voltage output modules. It utilizes an n-channel MOSFET shunt regulator and requires an auxiliary supply rail.

The values shown in Figures 1 and 2 are typical values. The value of R1 will depend on the module output voltage chosen. R3 is a power resistor that should be rated according to the maximum preload current required in the particular application. A value of 0.39ohm for R3 limits the maximum current in these circuits to about 2.6A for the Darlington circuit and 1.6A for the MOSFET circuit. If the full adjustment range of the module needs to be utilized, the power dissipating elements can be scaled to accommodate the Micro, Mini and Maxi modules.

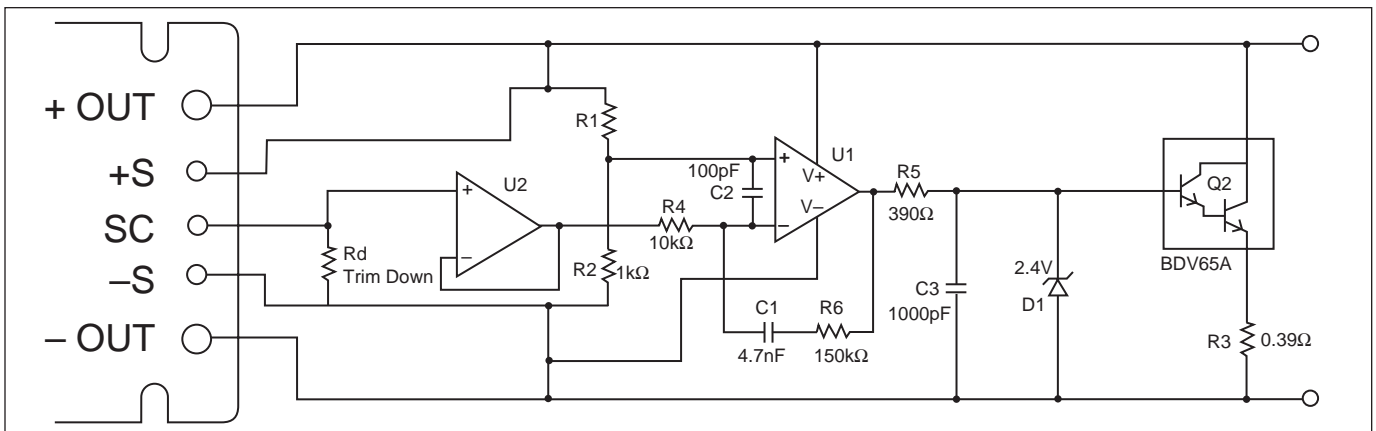

Figure 1. Preload circuit using a Darlington npn transistor

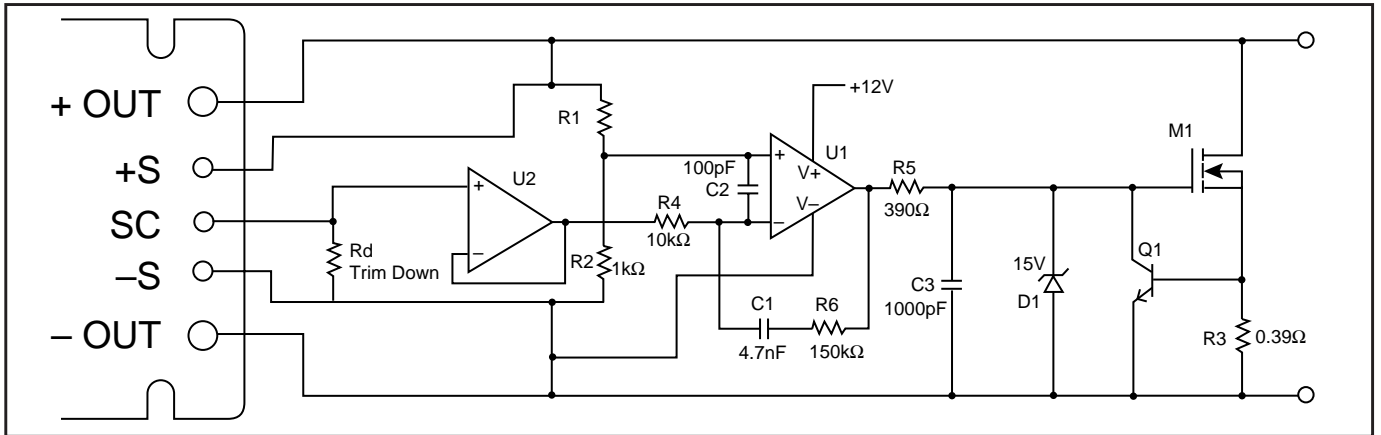

Figure 2. Preload circuit using an n-channel MOSFET shunt regulator

Both of these circuits function in a similar fashion. By comparing the voltage on the “SC” pin with the output voltage, the circuit will detect when the module is losing regulation. The load current will be increased by switching on Q2 or M1 until the module starts to regulate. C1 and R6 may require modification under some dynamic conditions.

Typical performance is shown in Figure 3. As the output voltage is decreased, the current flowing through the active preload will increase as required to maintain regulation.

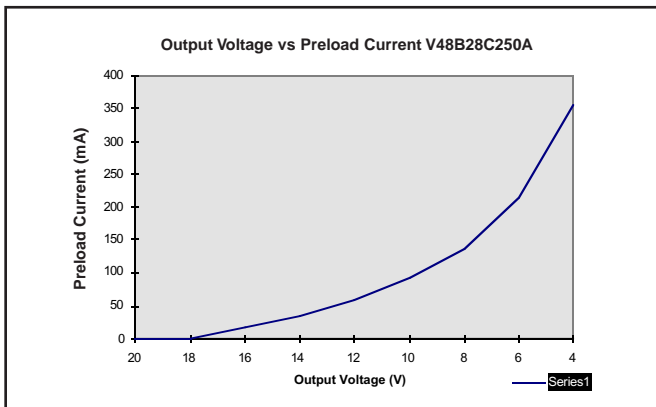

Figure 3. Typical preload current for a given output voltage

A 50mV error in programming is typical (when using an LM358 OP AMP and the output voltage is 10% of nominal) although this is masked by switching ripple. The choice of R1 and the type of OP AMP used will also affect any programming error.

R1 is chosen as follows. (1)

$$R1(k\Omega) = (1.01V_o - 1.23) \div 1.23$$

where  $V_o$  = Nominal Output Voltage

Please note R1 should always be rounded up to the nearest available resistor value. For example, 22k (would

be a suitable choice for a 28V output 2nd Generation module. This will ensure that the regulator is not continuously on when it is not needed. Worst-case tolerances can be accounted for by increasing the multiplication factor in equation 1 from 1.01 to 1.04. Testing may be required if an accurate threshold voltage is required for improved regulation.

These circuits can be applied to Vicor’s 1st Generation products as well. In this case, R1 should be chosen as:

$$R1(k\Omega) = (1.01V_o - 2.5) \div 2.5 \quad (2)$$

The preload current will be dependent on the nominal output voltage of the module and its power rating. When the output voltage is programmed near the minimum value, a preload requirement of 10% of the modules nominal output power rating may be required.

Consideration should be given to properly heatsink the power Darlington or MOSFET.

Some power system applications might introduce conditions or results that differ from those described. For more information or to discuss your specific application requirements, please contact Vicor Applications Engineering at 1-800-927-9474.