

CONDUCTED NOISE

Conducted noise is the AC current flowing between the source voltage and the power supply. It includes both common-mode and differential-mode noise. Vicor zero-current-switching converters are 20 – 40 dB lower in conducted noise than a traditional board-mounted PWM converter; however, if a specific EMC specification such as FCC or VDE must be met, additional filtering may be required.

Since the noise generated is ten to a hundred times lower than fixed frequency converters, an existing filter should provide equal or better performance when the conditions in the [Module Do's and Don'ts](#) section are followed. (Section 3)

In the event the system does not contain an existing filter, the following will provide valuable information relative to the attainment of system conducted noise objectives. System requirements, such as Tempest (military) or UL544/EN60601 (medical), require a somewhat different approach. Medical requirements vary as a function of the application and country — please contact Vicor Applications Engineering for additional details.

Common-Mode Noise with No Additional Filtering.

Common mode conducted noise current is the unidirectional (in phase) component in both the +IN and –IN pins to the module. This current circulates from the converter via the power input leads to the DC source and returns to the converter via the grounded baseplate or output lead connections. This represents a potentially large loop cross-sectional area which, if not effectively controlled, can generate magnetic fields. Common-mode noise is a function of the dv/dt across the main switch in the converter and the effective input to baseplate and input to output capacitance of the converter.

The most effective means to reduce common-mode current is to bypass both input leads to the baseplate with Y-capacitors (C2), keeping the leads short to reduce parasitic inductance. Additionally, a common-mode choke (L1) is usually required to meet FCC/VDE A or B. (Figure 9–2)

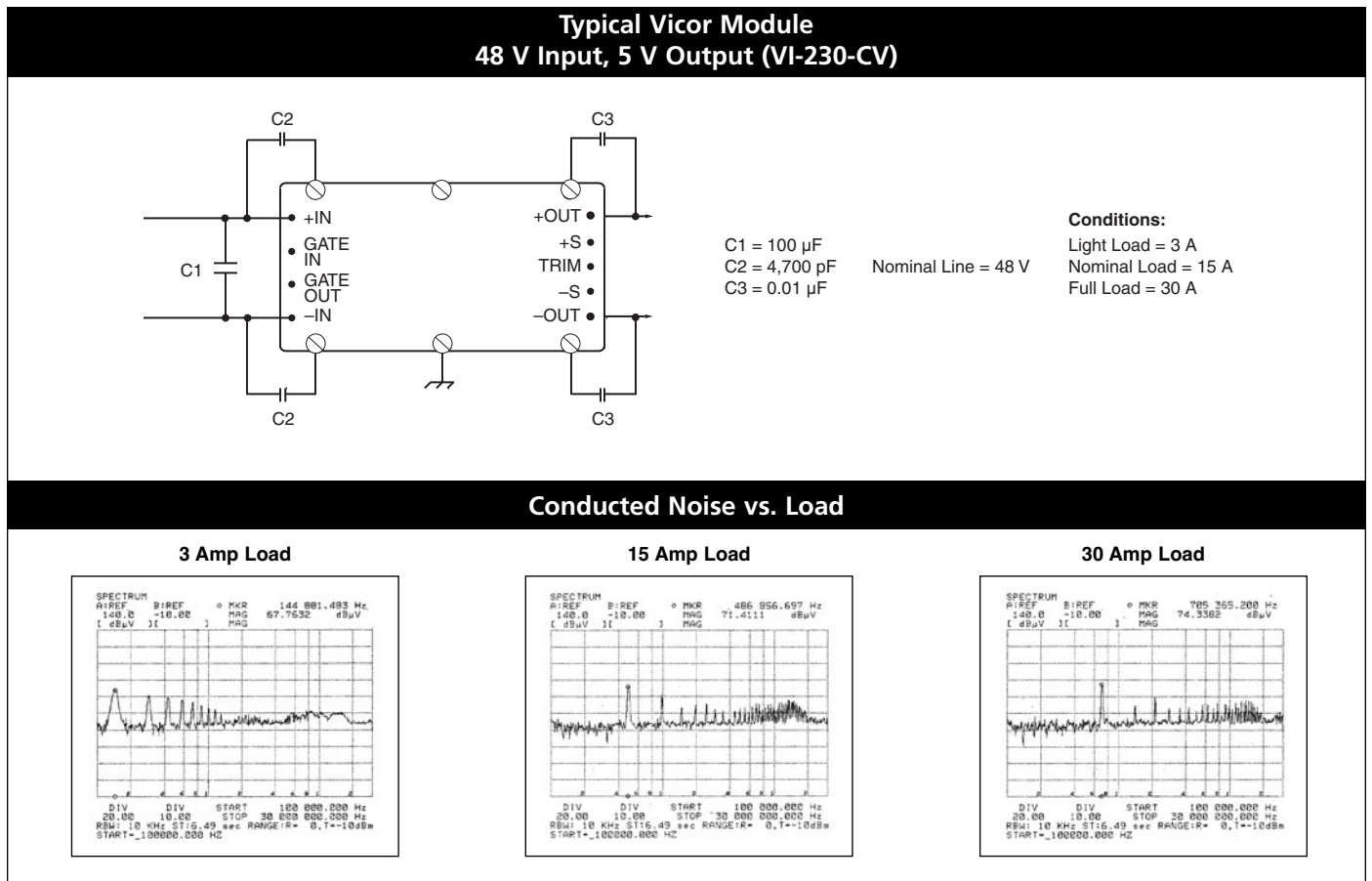

Figure 9–1 — Conducted input noise, no additional filtering

Common-Mode Noise with Common-Mode Choke.

There are no special precautions that must be exercised in the design of input filters for Vicor converters. In fact, if the system contains an EMC filter designed for typical fixed frequency converters, it should be sufficient as is (although not optimal in terms of size), as zero-current-switching converters inherently generate significantly less conducted noise.

NOTE: In most cases, a fixed frequency converter generates more input conducted noise with a filter than Vicor's zero-current-switching converter without a filter. Also note that fixed frequency converters using a construction technique involving control circuitry on the same metal plate as power processing components will generate significantly more input noise than shown.

The plots in Figure 9–2 are representative of fixed frequency converters with input filtering.

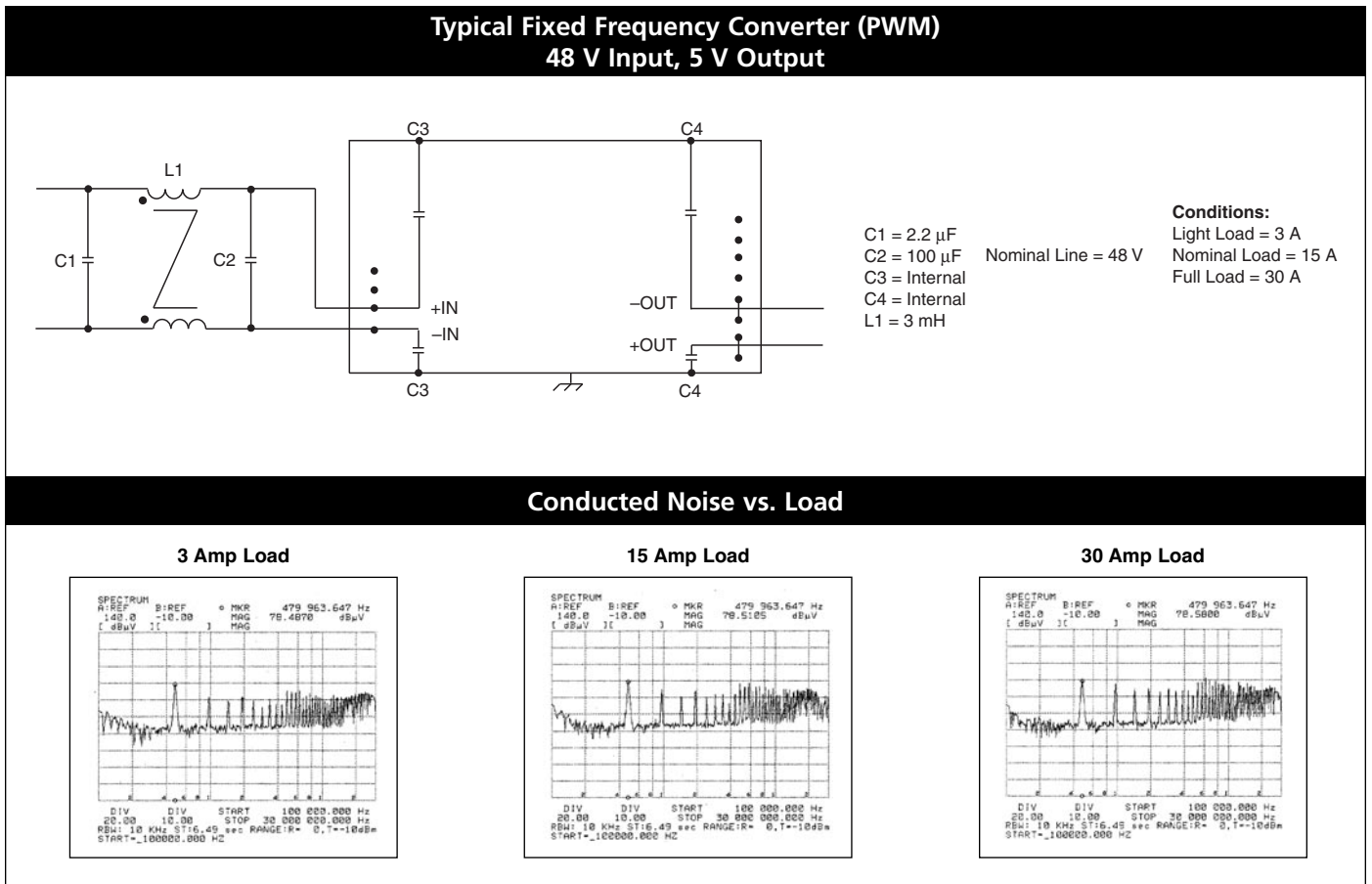
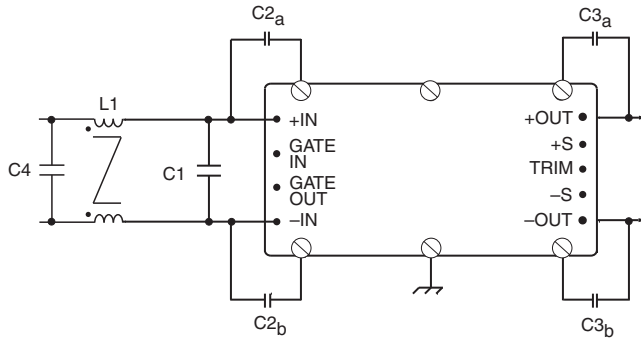

Figure 9–2 — Conducted input noise, typical fixed frequency converter with filter

**Typical Vicor Module (VI-230-CV)
48 V Input, 5 V Output**



- C1 = 100 μ F
- C2_a – C2_b = 4,700 pF (Vicor Part # 01000)
- C3_a – C3_b = 0.01 μ F (Vicor Part # 04872)
- C4 = 2.2 μ F
- L1 = 3,000 μ H (Vicor Part # 31742)

Conditions
 Light Load = 3 A
 Nominal Load = 15 A
 Full Load = 30 A

Three common-mode chokes are offered as standard accessories.

Part Number	Inductance Each Winding	Maximum DC Current	Resistance Each Winding
31743	1,000 μ H	12 Amperes	6.5 m Ω
31742	3,000 μ H	7 Amperes	18 m Ω
31943	2,163 μ H	1 Ampere	42 m Ω

NOTE: Common-mode filters may be common to one or more modules, but only one should be used with modules interconnected via GATE IN's or GATE OUT to GATE IN. As an example, Driver / Booster arrays or Drivers with GATE IN's tied together to provide a common disable function.

Conducted Noise vs. Load

3 Amp Load

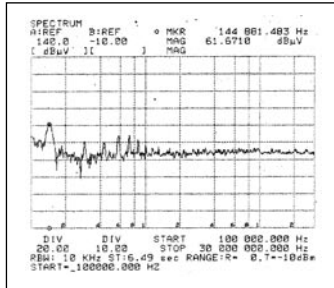

15 Amp Load

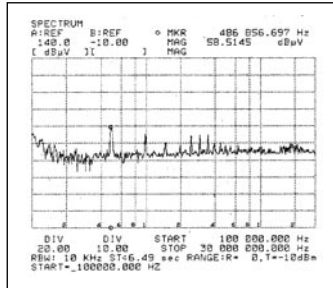

30 Amp Load

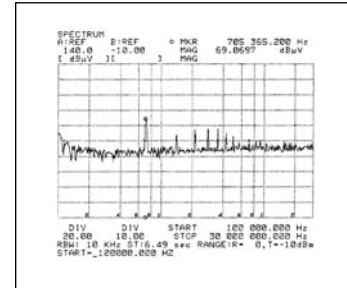
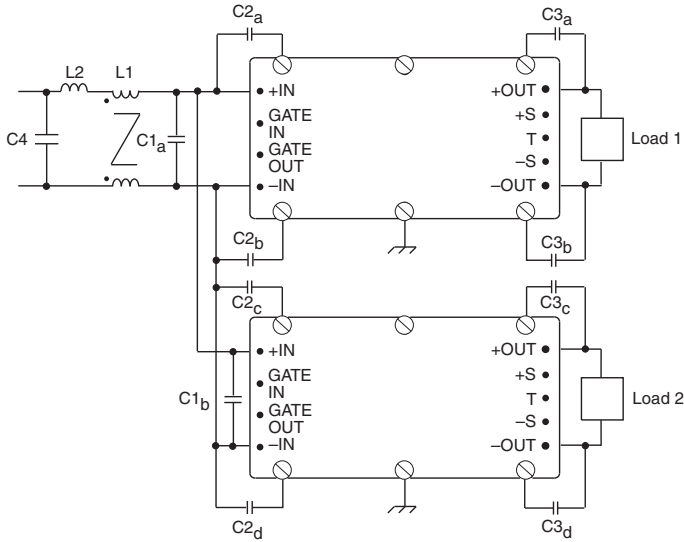

Figure 9-3 — Conducted input noise, with common-mode choke

Differential and Common-Mode Filter with More than One Module. No special precautions are needed when using two or more modules. The filter required will have the same characteristics as a single module filter,

however the wire size on the magnetics will need to reflect the increased input current. Shown below is the input conducted noise for two modules sharing a common input source.

Differential and Common-Mode Filter with More than One Module
48 V Inputs, 5 V Outputs (Two Vicor VI-230-CV Modules)



- C1_a – C1_b = 47 µF
- C2_a – C2_d = 4,700 pF (Vicor Part # 01000)
- C3_a – C3_d = 0.01 µF (Vicor Part # 04872)
- C4 = 2.2 µF
- L1 = 3,000 µH (Vicor Part # 31742)
- L2 = 20 µH

Conditions
 Light Load = 3 A
 Nominal Load = 15 A
 Full Load = 30 A

Three common-mode chokes are offered as standard accessories.

Part Number	Inductance Each Winding	Maximum DC Current	Resistance Each Winding
31743	1,000 µH	12 Amperes	6.5 mΩ
31742	3,000 µH	7 Amperes	18 mΩ
31943	2,163 µH	1 Ampere	42 mΩ

NOTE: Common-mode filters may be common to one or more modules, but only one should be used with modules interconnected via GATE IN's or, GATE OUT to GATE IN. As an example, Driver / Booster arrays or Drivers with GATE IN's tied together to provide a common disable function.

Conducted Noise vs. Load

3 Amp / 3 Amp Load

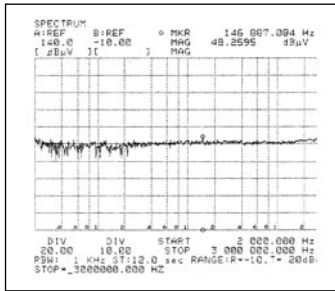

3 Amp / 6 Amp Load

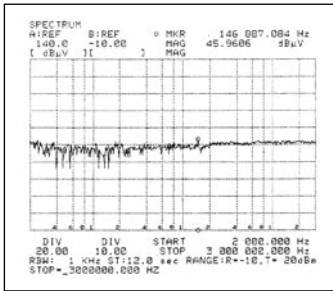

3 Amp / 30 Amp Load

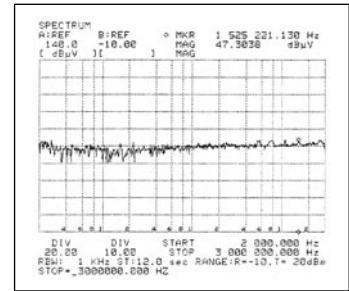

15 Amp / 15 Amp Load

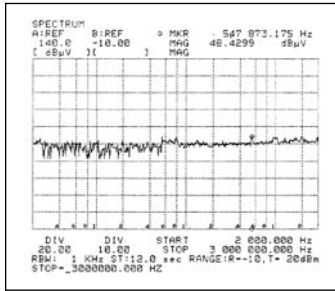

15 Amp / 30 Amp Load

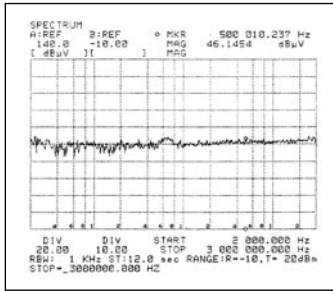

30 Amp / 30 Amp Load

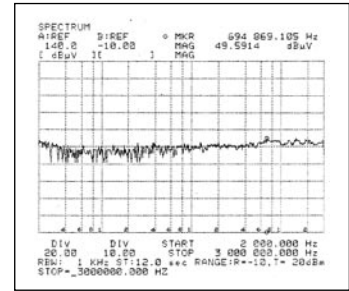

Figure 9-4 — Conducted noise, multiple zero-current-switching converters

Differential-Mode Noise Filter. Differential-mode conducted noise current is the component of current, at the input power pin, which is opposite in direction or phase with respect to the other input power pin.

All Vicor converters have an internal differential-mode LC filter which, in conjunction with a small external capacitor

$$C1 \text{ (minimum value in } \mu\text{F)} = 400 / V_{in}$$

reduces differential-mode conducted noise. The external capacitor should be placed close to the module to reduce loop cross-sectional area.

Care should be taken to reduce the loop cross-sectional area of differential-mode current flowing between the source and C1. Since differential-mode input current is by definition opposite in phase, twisting the input leads causes noise cancellation. PCB power planes can reduce radiated noise if the traces are on opposite sides of the PCB directly over one another. If differential mode inductance is used, it may be common to one or more modules.

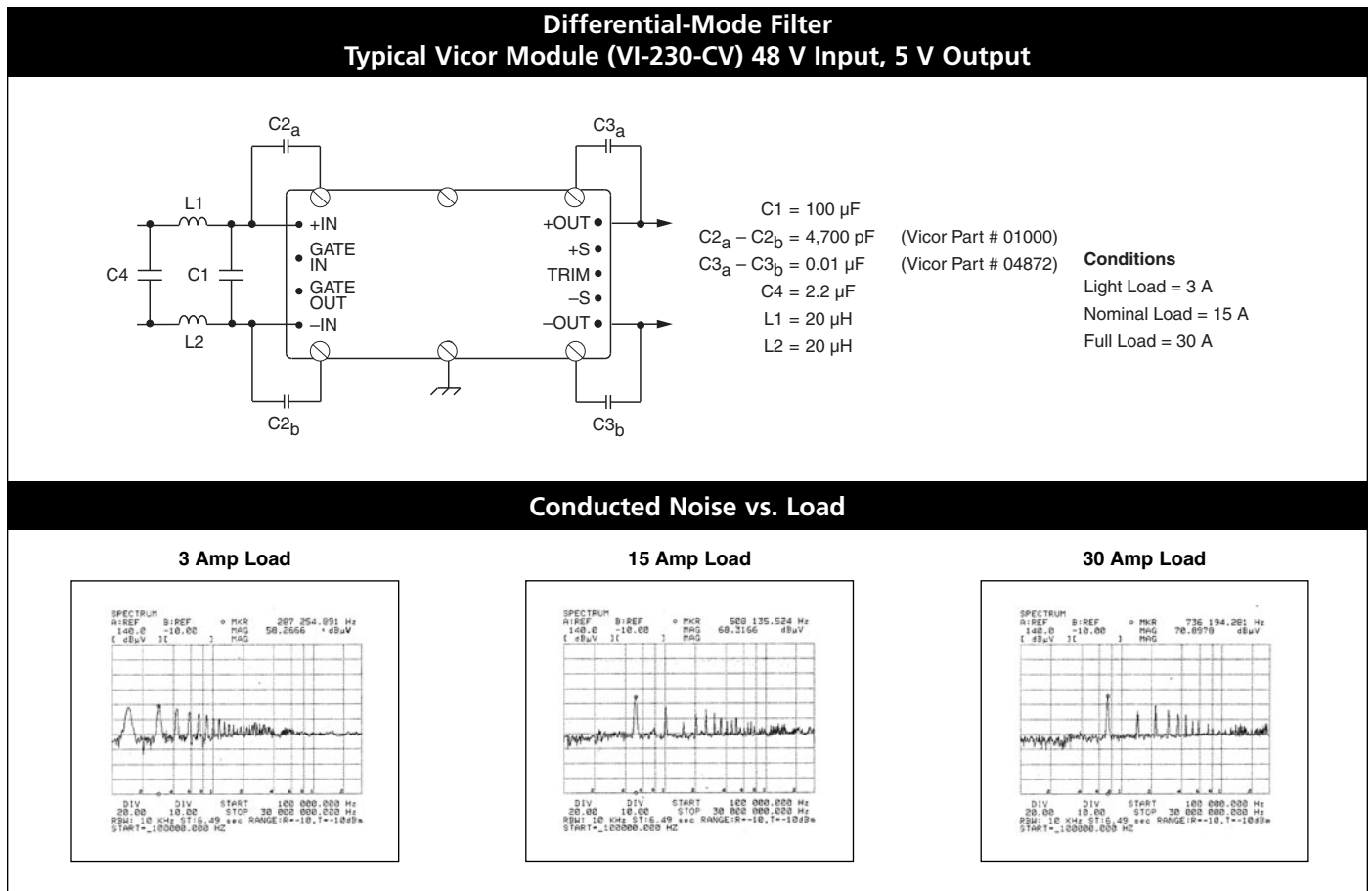

Figure 9–5 — Conducted noise, differential-mode filtering

RADIATED NOISE

Radiated noise may be either electric field or magnetic field. Magnetic radiation is caused by high di/dt and is generally what is measured by FCC, VDE or MIL-STD-461. Vicor converters utilize zero-current-switching, with the advantage over PWM non-zero-current-switching being that zero-current-switching topologies contain minimal discontinuities in the switched current waveforms, resulting in lower di/dt 's. Electric field radiation (caused by dv/dt) is "near-field," i.e., it decays rapidly as a function of distance and as a result does not typically affect radiated measurements.

Radiation can be minimized by proper board layout. Keep all leads with AC current short, twisted or routed as overlapping planes to minimize loop cross-sectional area.

Also keep in mind the effects of capacitive coupling — even when not expected. Do not put an unshielded filter on the opposite side of the PCB from the module. Conducted noise can be capacitively coupled around the filter. Do not route input and output leads in the same cable bundle. Again, no special precautions, just good design practice.

NOISE CONSIDERATIONS

All switchmode power supplies generate a certain amount of "noise", yet it remains one of the least understood parameters in power conversion.

VI-200s and VI-J00s both use the same topology, so their operation is very similar. These products are zero-current-switching converters — i.e., the current is zero when the main switch is turned on or off. While the switch is on, the current through the switch or the primary of the transformer is a half-wave rectified sine wave. Similar in operation to a resonant converter, these products are commonly referred to as quasi-resonant converters. The LC resonant frequency is fixed so the on-time of the switch is about 500 ns. When the switch turns on, energy builds up in the leakage inductance of the transformer (L) and then "transferred" into the capacitor on the secondary side of the module. (C, Figure 9–6) The energy processed in each pulse is fixed, and is ultimately the energy stored in this capacitor, $1/2 CV^2$. Since the energy in every pulse is fixed, the repetition rate of the pulse train is varied as a function of load to regulate the output voltage. Maximum repetition rate occurs at minimum line, full load and is approximately twice the LC time period or 1 μ s. If the load drops by 50%, then the repetition rate is approximately one-half of maximum (since the energy in every pulse is fixed). Therefore the pulse repetition rate varies linearly with load, to a first order approximation.

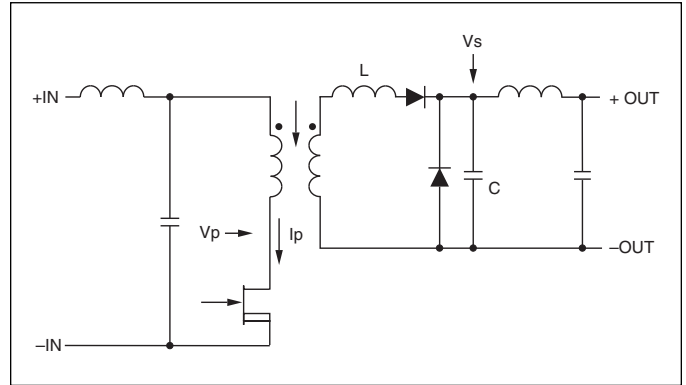

Figure 9-6 — Basic zero-current-switching converter topology (VI-200 / VI-J00)

Since the energy in every pulse is related to the square of the applied voltage (CV^2), the pulse repetition rate varies as approximately the square of the line voltage. For example, a 300 V input unit can vary from 200 – 400 V, or a factor of two, therefore it follows that the repetition rate must vary by approximately a factor of four to regulate the output. As previously established, the current in the primary is a half-wave rectified sine wave, but the voltage on the primary is a square wave. Since this voltage is a square wave, it contains harmonics of the fundamental switching frequency. It also includes frequencies, that extend to 70 MHz.

These frequencies can be of interest in the following circumstances. Rapidly changing voltages (high dv/dt) can generate E-fields (primarily near-field) which do not usually cause system noise problems since they significantly decrease as a function of distance. For this reason, E-fields are not measured by agencies such as the FCC or VDE. These agencies do, however, measure the magnetic radiation caused by high frequency currents in a conductor. The half-wave rectified sine wave in the transformer is an example of this, but since there are minimal discontinuities in the current waveform and the loop cross-sectional area is very small, the resultant E-field is very small. E-fields can be a problem if sensitive circuitry is located near the module. In this case, a shield can be positioned under the label side of the module as a discrete element or as a ground plane on the PCB. The other effect that occurs as a result of the 50 – 70 MHz component on the main switch is common-mode noise. (Figure 9–7)

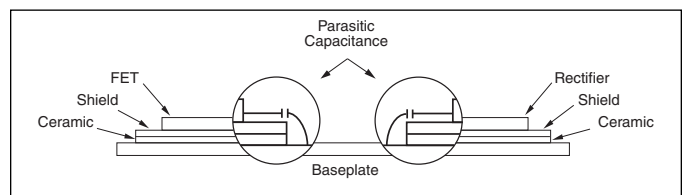

Figure 9-7 — The shield layer serves to reduce the capacitance

The dv/dt of the switch (FET) is a noise generator. This FET is mounted on a two layer insulating and shielding assembly which is attached to the baseplate. Since ceramic is a dielectric, there is capacitance from the FET to the baseplate. (Figure 9–7) The output rectifiers are also tied to the baseplate with ceramic insulators, adding additional capacitance. The dv/dt of the FET is differentiated by these two series capacitors, resulting in a spike of noise current at 50 – 70 MHz that flows from primary to secondary. (Figure 9–8) This noise current is common-mode as opposed to differential, and therefore should not affect the operation of the system. It should be noted, however, that oscilloscopes have a finite ability to reject common-mode signals, and these signals can be abnormally emphasized by the use of long ground leads on the scope probe.

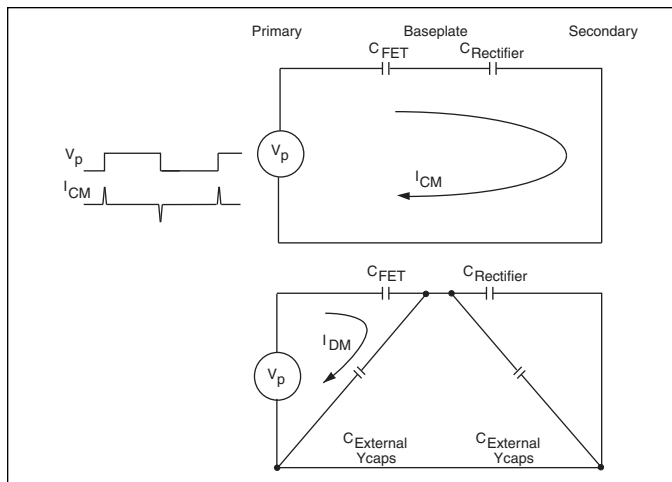

Figure 9–8 — Noise coupling model

MEASURING OUTPUT NOISE

Long ground leads adversely impact the common-mode rejection capability of oscilloscopes because the ground lead has inductance not present on the signal lead. These differing impedances take common-mode signals and convert them to differential signals that show up on the trace. To check for common-mode noise, place the oscilloscope probe on the ground lead connection of the probe while the ground lead is tied to output return. (Figure 9–9) If the noise is common-mode, there will still be “noise” observed at the same test point.

NOTE: The output return must be at the same relative potential as the earth ground of the oscilloscope or damaging current may flow through the oscilloscope ground lead.

Capacitors are required from the +/-IN to the baseplate thereby shunting common-mode current, thus reducing noise current on the input power lines. The capacitor must

have very short leads since the frequency is high. It must also be a good capacitor (i.e., ceramic or other material that has a low ESR / ESL). This type of capacitor is most important on high input voltage units since the “ dv ” is larger, but is required for all units. For off-line applications this capacitor must have the appropriate safety agency approvals.

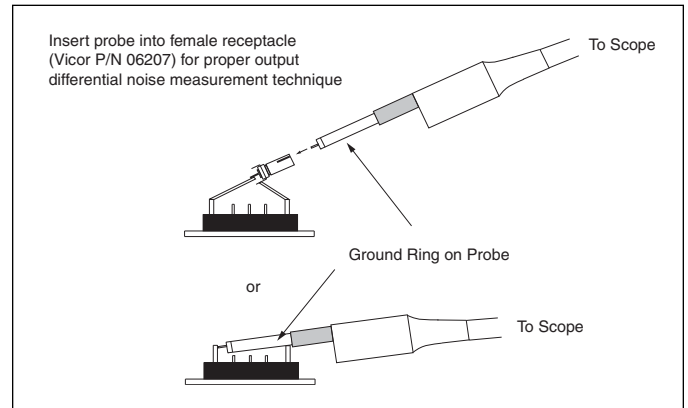

Figure 9–9 — Output ripple measurement technique

A capacitor from +/-Vout to the baseplate, is required since the output rectifier has a changing voltage on it, and, like the FET, can generate common-mode noise. This capacitor is similarly recommended for high output voltage units (48 V).

Common-mode noise is not differential with respect to the output. It does, however, flow in both input and output leads of the power supply and is a noise parameter that is measured by the FCC or VDE. It can cause power systems to fail radiated emission tests, so it must be dealt with. Bypass capacitors to the baseplate with a common-mode filter on the input of the module or the main input of the power supply is required.

The common-mode filter is typically placed on the input as opposed to the output. Theoretically, since this current flows from primary to secondary, the choke could be placed in either the input or the output, but is preferably placed in the input leads for the following reasons:

- 1) input currents are smaller since the input voltage is usually higher;
- 2) line regulation of the module can correct for voltage drops across the choke; and
- 3) if the choke is on the output and the senses are connected to the other side of it, the stability of the loop may be impacted.

Differential output noise is the AC component of the output voltage that is not common to both outputs. The noise is comprised of both low frequency, line-related noise (typically 120 Hz) and high frequency switching noise.

High Frequency Switching Noise. Peak-to-peak output voltage ripple is typically 2% or less (1% for 12 V outputs and above). Hence additional output filtering is generally not required. Digital systems rarely need additional filtering. However some analog systems, such as ultrasound systems, will probably require additional output filtering. See additional output filter choices in Table 9-1.

Line Related Output Noise. Line related output noise can be determined from the converter specification — Input Ripple Rejection. As an example, a VI-260-CV

(300 Vin to 5 Vout) has a rejection specification at 120 Hz of $30 + 20 \text{ Log} (V_{in} / V_{out})$. $V_{in} = 300$ and $V_{out} = 5$, hence its rejection is $30 + 35.56 = 65.56 \text{ dB}$, which provides an attenuation factor of 1.89 k. Therefore, if the input to the converter has 30 V p-p of ripple, the output p-p ripple would be 15.8 mV. It is not practical to attenuate this component further with passive filtering due to its low frequency, hence active filtering is required. The RAM contains both a passive filter for high frequency noise and an active filter for low frequency noise.

	5 V Outputs	12 – 15 V Outputs	24 – 48 V Outputs
No Additional Filter	2% p-p (Typical)	1% p-p (Typical)	0.2% p-p (Typical)
Low ESR Output Cap.	1% p-p (Typical)	0.5% p-p (Typical)	0.1% p-p (Typical)
LC Output Filter	0.4% p-p (Typical)	0.2% p-p (Typical)	0.05% p-p (Typical)
RAM Filter (VI-200)	<3 mV p-p (Maximum)	<3 mV p-p (Maximum)	<3 mV p-p (Maximum)
RAM Filter (VI-J00)	<10 mV (Maximum)	<10 mV (Maximum)	<10 mV (Maximum)

Table 9-1 — Output filter options and output voltage and ripple

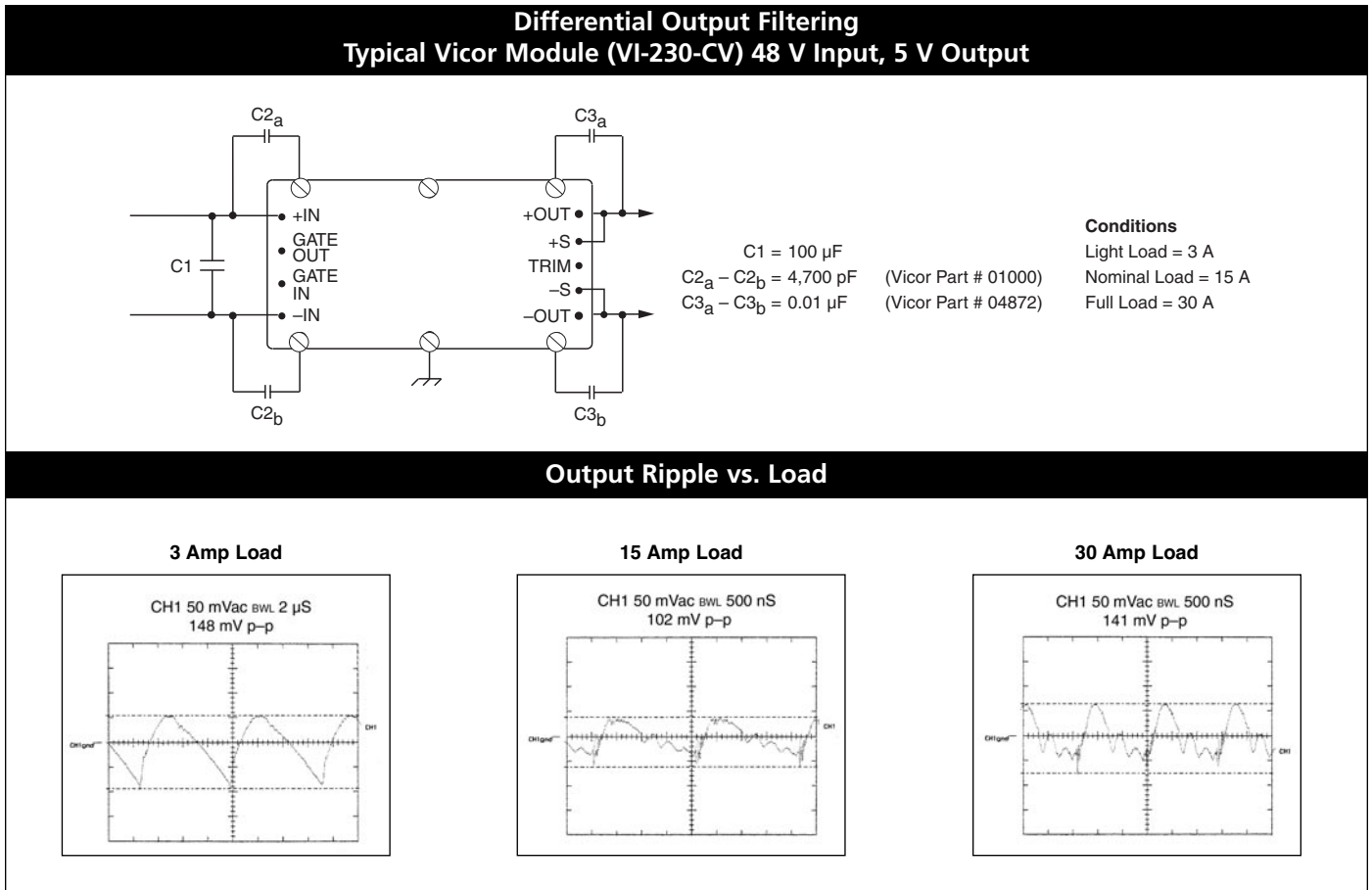

Figure 9-10 — Output noise, no additional output filtering

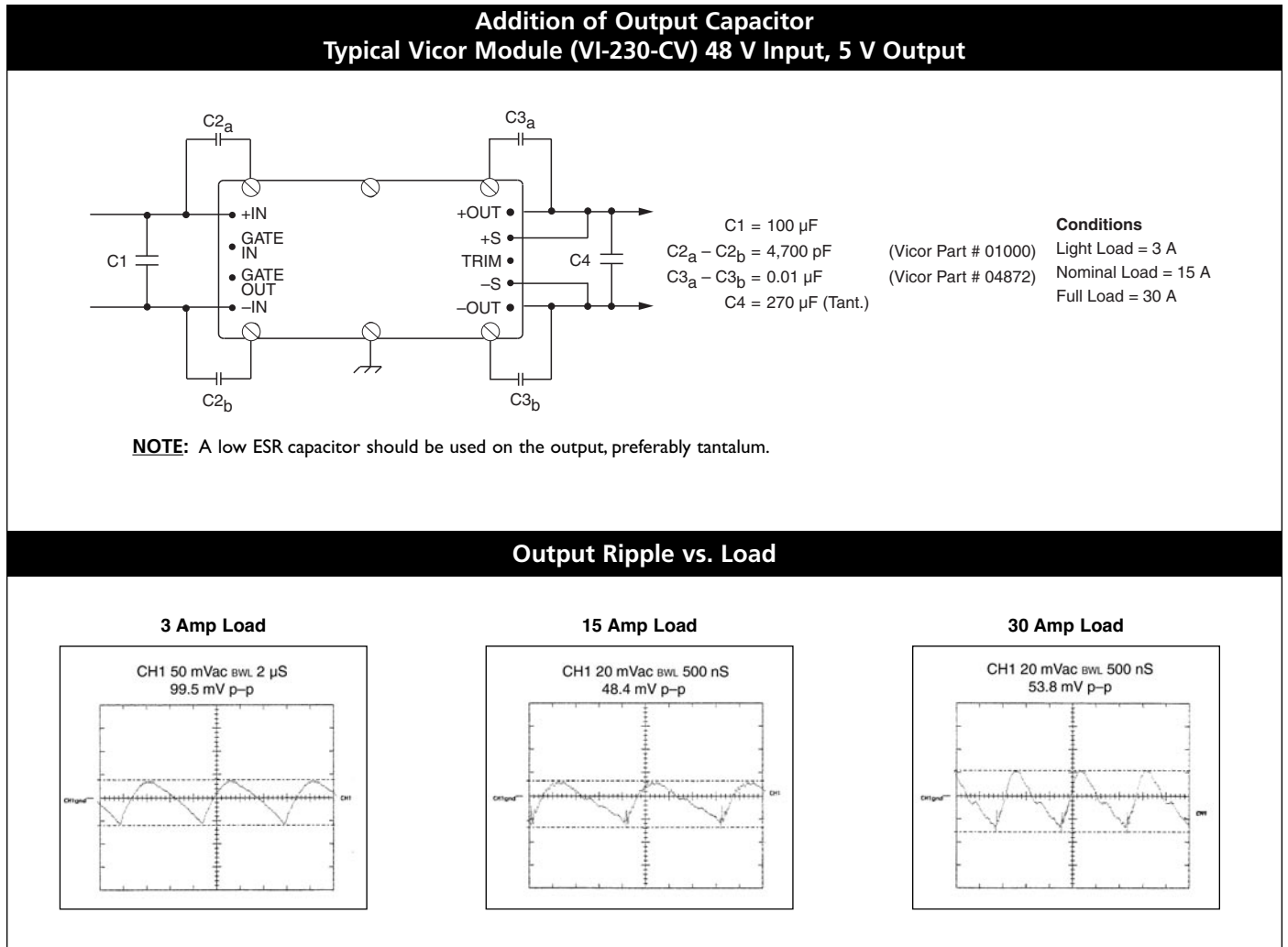

Figure 9-11 — Output noise, additional output capacitance

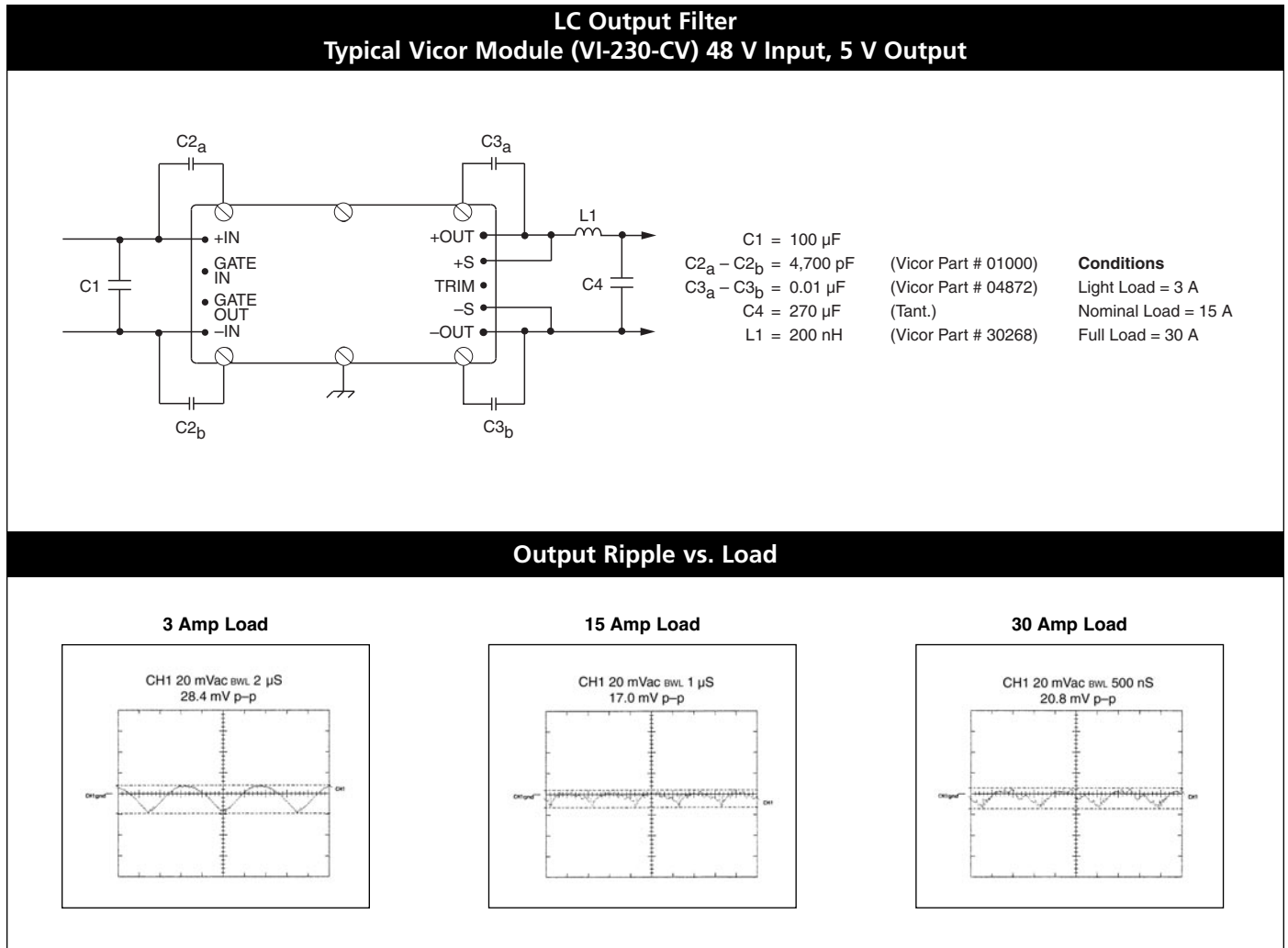

Figure 9-12 — Output noise, additional output inductor and capacitor (L-C Filter)

RAM / MI-RAM OPERATION

The RAM/MI-RAM attenuates output noise in two ways. First, an LC filter in the RAM/MI-RAM attenuates high frequency components associated with the switching frequency. Secondly, the RAM/MI-RAM contains an active filter that attenuates low frequency components associated with the input to the converter. These frequencies are on the order of 60 – 120 Hz and harmonics would require very large output LC if a passive approach were to be used. Essentially, the active circuit looks at the output ripple from the converter, multiplies it by -1 (inverts) and adds it to the output. This effectively cancels out the low frequency components.

The RAM does not contain any common-mode filtering, so whatever common-mode noise is present is passed through. It only provides differential filtering of noise that is present on one output pin relative to the other.

The use of the RAM/MI-RAM is very straightforward, but a couple of precautions should be noted. The LC filter is in the positive output lead, so if that lead is shorted then the high frequency attenuation is compromised. The active circuit is in the negative output lead, so if that lead is shorted the low frequency attenuation is compromised. The RAM must be used with a common-mode choke at the input of the converter.

The RAM is intended to be used with the Vicor VI-200/VI-J00, and the MI-RAM is intended to be used with Vicor MI-200/MI-J00 Family of DC-DC converter modules. It is also available in a chassis mounted version as VI-LRAM-xx (MegaMod package) or VI-RAM-xx-B1 (BusMod package).

NOTE: Do not use if load is inductive as instability may result. The addition of the RAM will increase the converter's current limit setpoint by ~ 14%.

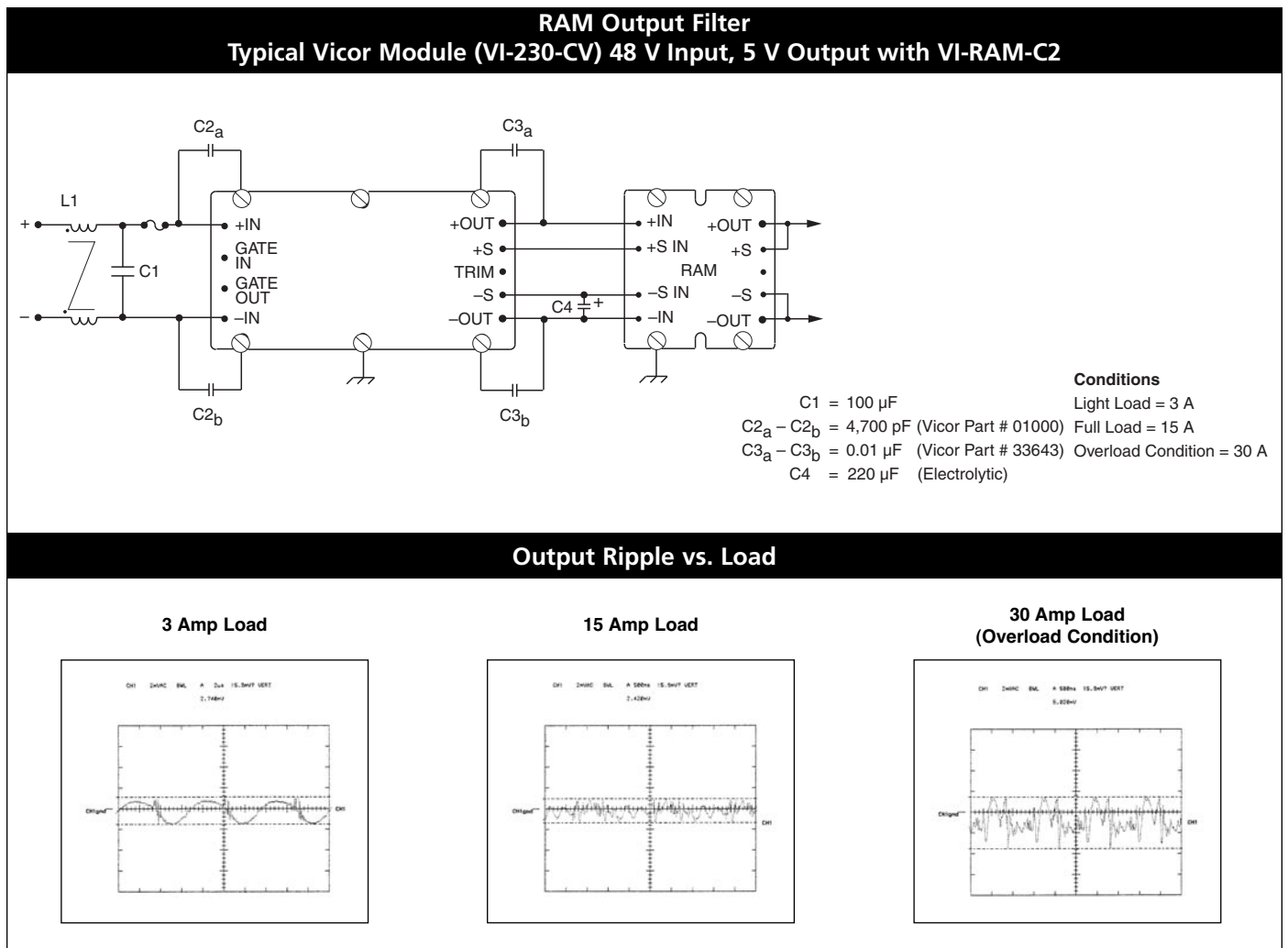

Figure 9-13 — Output noise, with Ripple Attenuator Module (RAM)